

GAMMA BRACING SYSTEMS

TECHNICAL
INSTALLATION MANUAL

 **GAMMA**

BRANZ Appraised
Appraisal No.1079

**NEW ZEALAND'S
MOST ADVANCED
BRACING SYSTEM
FOR TIMBER FRAME
CONSTRUCTION**

ISSUE MARCH 2026



DESIGNED BY GAMMA BRACING TECHNOLOGIES LTD
Copyright 2014



GBF220



GBF400

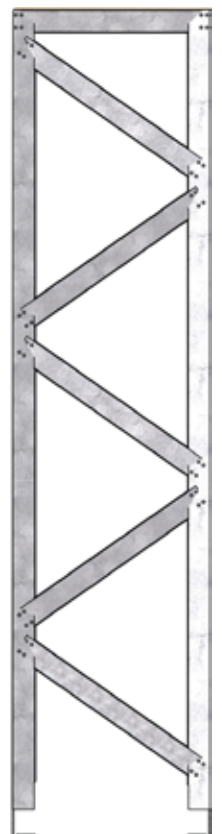

GBF600

1.0 General Information

1. Gamma Bracing Frames (GBFs) withstands multiple wind and/or earthquake traumas and maintains its structural integrity.
2. GBF has a high "Ductility" so it can flex without failure.
3. GBFs are best installed early in the construction to immediately provide bracing performance.
4. GBFs eliminate the majority of temporary bracing.
5. It's fast and easy to install either onsite or in a frame & truss plant.
6. GBF comes with pre-punched fixing & service holes.
7. GBFs are lightweight and of a robust construction (12.5kg).
8. GBFs are suitable for remedial work for buildings affected by leaky building syndrome.
9. GBFs can be installed in wet areas and areas where no linings are installed.
10. GBFs provide up to 150 BUs per metre (1 kN = 20 BUs).
11. GBFs have a conditional 50 year B2 durability.
12. GBFs are cost competitive within the total construction costs.
13. GBFs are suitable for standard timber framing, either 600, or 400/450 or 220mm stud spacing.
14. Effective on both Concrete and Timber bases.
15. Designed and manufactured for New Zealand environments.
16. 100% Recyclable so very small environmental footprint.
17. Will provide structural bracing for the lifetime of the building.
18. It is fully compliant with New Zealand Building Code.
19. GBFs may be used in combination with other bracing systems, eg. plasterboard and plywood.

Section No.	Description	Page
1.0	General Information	2
1.1	Introduction	4
1.2	Warranty	4
1.3	Benefits of using Gamma Bracing System	4
2.0	Compliance Statement	5
2.1	The New Zealand Building Code (NZBC)	5
2.2	Purpose of Product	5
2.3	Scope of acceptable use	5
2.4	Limitations of use	6
2.5	Who may install the Gamma Bracing System	6
2.6	Health & Safety	6
2.7	Compatibility with associated products	6
3.0	Performance & Construction	7
3.1	System Summary Table – Table 1	7
4.0	Gamma Bracing Software & Design Procedure	8
4.1	Gamma Bracing Software - Demand	8
4.2	Gamma Bracing Software - Achieved	9
5.0	Installation Procedure	10
6.0	Gamma Bracing Frame GBF220S	13
6.1	Gamma Bracing System GBF220S – Construction Drawing (Wall Height 2.1m)	14
7.0	Gamma Bracing Frame GBF220	15
7.1	Gamma Bracing System GBF220 – Construction Drawing (Wall Height 2.4m)	16
8.0	Gamma Bracing Frame GBF400S	17
8.1	Gamma Bracing System GBF400S – Construction Drawing (Wall Height 2.1m)	18
9.0	Gamma Bracing Frame GBF400	19
9.1	Gamma Bracing System GBF400 – Construction Drawing (Wall Height 2.4m)	20
9.2	Gamma Bracing System GBF400 – Construction Drawing (Wall Height 2.7m)	21
9.3	Gamma Bracing System GBF400 – Construction Drawing (Wall Height 3.0m)	22
10.0	Gamma Bracing System GBF535S – Construction Drawing (Wall Height 2.1m)	23
10.1	Gamma Bracing System GBF535 – Construction Drawing (Wall Height 2.4m)	24
10.2	Gamma Bracing System GBF535 – Construction Drawing (Wall Height 2.7m)	25
10.3	Gamma Bracing System GBF535 – Construction Drawing (Wall Height 3.0m)	26
11.0	Gamma Bracing Frame GBF600S	27
11.1	Gamma Bracing System GBF600S – Construction Drawing (Wall Height 2.1m)	28
12.0	Gamma Bracing Frame GBF600	29
12.1	Gamma Bracing System GBF600 – Construction Drawing (Wall Height 2.4m)	30
12.2	Gamma Bracing System GBF600 – Construction Drawing (Wall Height 2.7m)	31
12.3	Gamma Bracing System GBF600 – Construction Drawing (Wall Height 3.0m)	32
13.0	Gamma Bracing System GBPF – Gamma Bracing Portal Frame Construction Drawing (Wall Height 2.4m)	33
13.1	Gamma Bracing System GBPF – Gamma Bracing Portal Frame Construction Drawing (Wall Height 2.7m)	34
14.0	Construction Details – Construction Drawing – 2 x GBF600 (Wall Height 2.4m)	35
14.1	Construction Details - Construction Drawing – 2 x GBF600 (Wall Height 2.7m)	36
14.2	Construction Details – Construction Drawing – 2 x GBF600 (Wall Height 3.0m)	37
14.3	Construction Details – Construction Drawing – Multiple GBF600 Frames (Wall Height 3.0m)	38
14.4	Construction Details – Construction Drawing – Exterior Walls on Concrete Floors	39
14.5	Construction Details – Construction Drawing – Interior Walls on Concrete Floors	40
14.6	Construction Details – Construction Drawing – Exterior Walls on Timber Floors	41
14.7	Construction Details – Construction Drawing – Interior Walls on Timber Floors	42
14.8	Construction Details – Construction Drawing – Height Adjustment	43
15.0	Ancillary Products	44
15.1	Fasteners	44
15.2	Hold Down Anchors	44
15.3	Insulation	44
15.4	Electrical Equipment	45
15.5	Plumbing Equipment	45

1.1. Introduction

Gamma Bracing System technology has been specifically designed and rigorously tested in New Zealand to provide structural bracing for both residential and light commercial buildings within the scope and limitations of NZS3604:2011.

The Gamma Bracing System has been tested in accordance with the P21 {2010} racking test limited states design; cited in NZS3604 Timber Framed Buildings to determine wind and earthquake ratings of bracing elements. This aligns with the loadings standard AS/NZS 1170.

1.2. Warranty

The Gamma Bracing System carries the following warranty. This warranty is given by Gamma Bracing Technology Ltd ("The Manufacturer")

The manufacturer warrants that the products produced by the manufacturer shall be free of defects in materials and manufacture. If the products produced by the manufacturer do not meet the manufacturers standards, they will replace with the equivalent product. The manufacturer advises that only products, components and systems recommended by Gamma Bracing Technologies Ltd be used. At all times these must be used in accordance with the relevant product manufacturers usage recommendations.

If this is not done, the manufacturer will need to be satisfied that any defect in it's product is attributable to the failure of the manufactured product to meet the manufacturers standard (and not another clause) before this warranty applies. This warranty excludes all other warranties and liability for damage or loss in connection with the defects in the manufacturers product other than those imposed by legislation.

1.3. Benefits of using Gamma Bracing System

The design of the Gamma Bracing System allows for easy installation for both new and existing buildings. No additional, specialty bracing linings are required other than to provide standard interior finishings.

Once the Gamma Bracing System has been installed, the bracing requirements of the building are completed and therefore the need for temporary timber bracing is significantly reduced; saving time and cost as well as providing a safer working environment.

Inspection by the Building Consent Authority of the bracing system can be done early in the construction programme. No further inspections of bracing elements are required, thus another saving of time and money.

Using the Gamma Bracing System removes the need for other types of bracing such as galvanised straps, which connect the stud with the bottom plate. By removing the need for these straps a flatter surface is provided for the installation of the interior lining.

Provided the timber frame moisture levels, as detailed in NZS3604:2011 and NZS3602; are followed and the Gamma Bracing System is used in a closed environment, the Gamma Bracing frames once installed do not require maintenance. Provided the requirements of NZ Steel's Galvsteel® (Axxis 550) Durability Statement are met, the Gamma Bracing frames are unaffected by weather conditions.

Gamma Bracing frames are provided with a warning label advising that the structural integrity of the building must be maintained at all times. This is to prevent the possible removal or modification of the Gamma Bracing System during renovation work.

Each Gamma Bracing frame provides significant bracing values for both wind and earthquake demand. Total bracing integrity can be achieved wherever Gamma Bracing frames are positioned throughout the buildings structure.

2.1. The New Zealand Building Code (NZBC)

The Gamma Bracing System when installed in accordance with the installation details will comply with the New Zealand Building Code requirements as detailed in this document.

Clause B1 STRUCTURE: Performance B1.3.1, B1.3.2 and B1.3.4 Gamma Wall Bracing Systems meet the requirements for loads arising from earthquake and wind [ie. B1.3.3 (f), and (h)].

Clause B2 DURABILITY: Performance B2.3.1 (a) not less than 50 years. Gamma Wall Bracing Systems meet this requirement.

Clause F2 HAZARDOUS BUILDING MATERIALS: Performance F2.3.1 Gamma Wall Bracing Systems meet this requirement and will not present a health hazard to people.

The bracing demand calculation and bracing distribution rules contained in the Gamma Wall Bracing Systems Software are in accordance with Section 5 of NZS 3604, Bracing resistance is provided by bracing element ratings determined in accordance with NZS 3604, Paragraph 8.3.1.2.

Bracing Resistance is provided by bracing element ratings determined in accordance with NZS3604, Paragraph 8.3.1.2.

2.2. Purpose of product

To provide a durable, reliable and cost effective building element for the structural and bracing performance levels as specified within this manual.

2.3 Scope of acceptable use

Acceptable use as structural bracing systems for both residential and light commercial buildings and within the scope and limitations of NZS3604:2011.

If the Gamma Bracing System is to be considered for installation other than in accordance with the manual, specific engineering will be required.

The Gamma Bracing frame is located within the cavity of the wall and is not to be exposed to external weather conditions. The frame is manufactured from materials that have protective coatings to resist corrosion during the construction period.

2.4. Limitations of use

For use:

- In the interior cavity of internal and external walls in accordance the manufacturers installation instructions.
- To be used within the scope and limitations of NZS3604:2011

2.5. Who may install the Gamma Bracing System

Installation of the Gamma Bracing System must be undertaken or the installation be installed by a Licensed Building Practitioner with the appropriate license category where the building work has been identified as Restricted Building Work.

2.6. Health & Safety

It is important to follow good site practice at all times and to ensure appropriate safety precautions are taken when installing the Gamma Bracing System and all supporting components.

2.7. Compatibility with associated products

The Gamma Bracing System and its components are compatible with most associated building products, however it is recommended that the installer refers to NZS3604:2011 Section 4 Durability to ensure compatibility with other materials.

The performance and construction of the Gamma Bracing Systems is detailed in Table 1. The values for wind and earthquake bracing ratings are obtained from testing and evaluation that has been carried out in accordance with NZS3604:2011 and P21[2010] and evaluation procedures.



3.1 SYSTEM SUMMARY TABLE

Gamma System Reference	Performance & Construction								Page #
	Performance Bracing Units (BUs)		Stud Qty & Configuration (Min Stud Size 90 x 45mm)			System Size Including Framing			
	Wind	Earth	Stud Centres (mm)	Left Side	Right Side	Wall Length (m)	Minimum Wall Height (m)	Maximum Wall Height (m)	
GBF220S/2.1	37	44	310	2	2	0.4	2.1	2.4	14
GBF220/2.4	37	44		2	2		2.4	2.7	16
GBF400S/2.1	45	55	400	1	1	0.445	2.1	2.4	18
GBF400/2.4	45	55		1	1		2.4	2.7	20
GBF400/2.7	40	47		1	1		2.7	3.0	21
GBF400/3.0	35	44		1	1		3.0	3.3	22
GBF535S/2.1	69	75	400	2	2	0.535	2.1	2.4	23
GBF535/2.4	69	75		2	2		2.4	2.7	24
GBF535/2.7	61	67		2	2		2.7	3.0	25
GBF535/3.0	55	60		2	2		3.0	3.3	26
GBF600S/2.1	84	90	600	1	1	0.6	2.1	2.4	28
GBF600/2.4	84	90		1	1		2.4	2.7	30
GBF600/2.7	70	70		1	1		2.7	3.0	31
GBF600/3.0	55	60		1	1		3.0	3.6	32

Portal System Reference	Performance Bracing Units (BUs)		Maximum Wall Height (mm)	Maximum Opening (mm)	Maximum Portal Length (mm)	Page #
	Wind	Earth				
GBFP/2.4	124	137	2400	5200	6000	33
GBFP/2.7	110	122	2700			34

COMBINATIONS OF GBF TYPES - TYPICAL SYSTEMS

	Wind	Earth		Wind	Earth
GBF220/2.4 + GBF600/2.4	(37 + 84)	(44 + 90)	2	220mm + 645mm	2400mm
GBF400/2.4 + GBF600/2.4	(45 + 84)	(55 + 90)	1	220mm + 645mm	2400mm
GBF220/2.4 + GBF535/2.4	(37 + 69)	(44 + 75)	2	45mm + 535mm	2400mm

OR ANY OTHER COMBINATION TO MEET DESIRED DESIGN AND BRACING REQUIRED.

The Gamma Bracing System provides bracing performance to resist and achieve Wind and Earthquake demands. To calculate both the Wind and Earthquake demands Gamma Bracing Technologies Ltd has developed a spread sheet calculator that is in accordance with the requirements of the NZS3604:2011 Standard. This section details the method of calculating both the demand and achieved requirements using the Gamma spread sheet calculator. The Gamma Bracing Technologies Ltd spread sheet calculator can be easily downloaded from the Gamma web site www.gambracing.co.nz.

4.1 Gamma Bracing Software - Demand

The Gamma Bracing Calculator Software has been designed to work in conjunction with NZS3604:2011.

The Demand and Achieved sheets within the Gamma Bracing Calculator software allow for a fast and simple way to calculate the structural bracing requirements of a timber framed structure.

The Gamma Bracing Software is preloaded with Gamma Bracing Systems values. The software allows the user to use other bracing systems. (Other bracing system values will require loading into the designated calculation sheets by the user – refer to terms and conditions).

It is acceptable to use a combination of different bracing systems along the same bracing line. However it is not permitted to place more than one bracing element in the same position.

Designing the structural aspects of a building require a good knowledge and understanding of the principles of building timber framed structures.

Instructions

Project Details

Type in the name of the owner and the property address details including the Lot number and the DP number. Details for the Architect, Designer and Engineer can also be added should they be required.

Calculating the Demand

Input the information of the building into the required cells. Cells with drop down lists provide options to choose from – choosing the “specify” option allows for a custom option or value to be loaded.

Building dimensions, roof and wall cladding weights need to be inputted to enable a bracing demand to be calculated. Incorrect information or information not inputted will not provide a result and a warning notification will be indicated.

Wind demand requirements can be further refined by choosing from the drop down lists in the Yellow panel.

Gamma Bracing solution V1

Job Description - what is typed here will be reproduced on print sheet.

Warning. This spreadsheet calculates the bracing rating for the building defined. It does not check that the building defined complies NZS 3604 scope.

Building and roof description

How many storeys above slab or subfloor?

Foundation type

RoofH = Roof height above eaves (m)

LR = Maximum roof length (m)

WR = Maximum roof width (m)

Roof pitch (degrees)

Specified maximum pitch (degrees) option

Room in roof space?

Roof cladding weight

Specified roof cladding weight option (kg/m²)

Floor live load

Specified floor loading option (kPa)

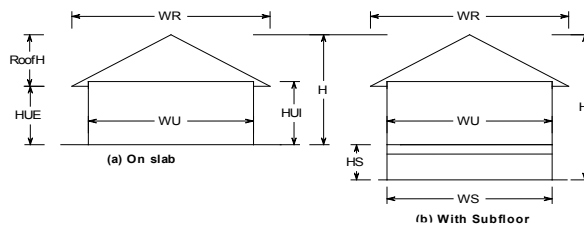

Single storey building definitions

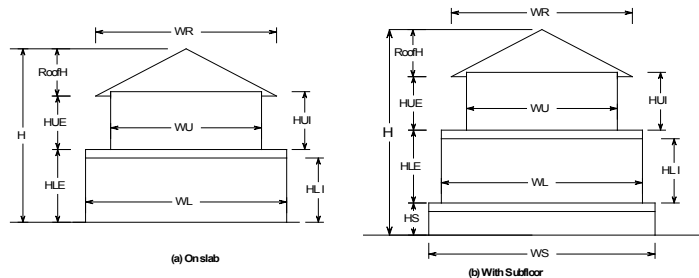

Two storey building definitions

Upper or single storey details

Average exterior wall cladding weight

Specified wall cladding weight option (kg/m²)

LU = Building length (m)

WU = Building width (m)

Gross building plan area (m²)

HUI = Interior wall height (m)

HUE = Exterior wall height (m)

Lower storey details

Average exterior wall cladding weight

Specified wall cladding weight option (kg/m²)

LL = Building length (m)

WL = Building width (m)

Gross building plan area (m²)

HLI = Interior wall height

HLE = Exterior wall height

Subfloor details

Average exterior wall cladding weight

Specified wall cladding weight option (kg/m²)

LS = Building length (m)

WS = Building width (m)

Gross building plan area (m²)

HS = Subfloor height

Wind speed

Choose which option you wish to use to specify wind speed. (a) Specify the wind zone such as from Table 5.4 of NZS 3604.

(b) Specify the wind speed in m/sec directly in the adjacent blue cell. Wind speed = m/sec

(c) Get the wind speed calculated in the yellow zone below as per Table 5.1 of NZS3604.

Wind Zone

Wind Region from Figure 5.1 of NZS 3604

Roughness from Section 5.2.3 of NZS 3604

Exposure from Section 5.2.4 of NZS 3604

Is it a Lee Zone - see Figure 5.1 of NZS 3604?

Topography from Section 5.2.5 of NZS 3604

Wind zone determined = Very High

Earthquake Zone from Figure 5.4 of NZS 3604

Subsoil classification from Section 5.3.3 of NZS 3604

Summary of bracing demand and resistance:

	Upper storey		Lower storey		Subfloor	
	Demand	Provided	Demand	Provided	Demand	Provided
Total Wind Demand/Provided in BU's						
Wall along direction	0	0	4	0	4	0
Wall across direction	0	0	0	0	0	0
Total EQ Demand/Provided in BU's						
Wall along direction	#DIV/0!	0	#DIV/0!	0	#DIV/0!	0
Wall across direction	#DIV/0!	0	#DIV/0!	0	#DIV/0!	0
Check of bracing capacity						
Wall along direction	OK		Inadequate		Inadequate	
Wall across direction	OK		OK		OK	

4.2 Gamma Bracing Software - Achieved



CALCULATING THE ACHIEVED

The bracing calculation sheets listed below are available within the Gamma Bracing software to calculate the bracing achieved requirements for house types that are accordance with the NZS3604:2011 standard. Depending on the type of house refer to Table 2 when choosing the achieved sheets

- Subfloor Along Sheet
- Subfloor Across Sheet
- Lower Along Sheet
- Lower Across Sheet
- Upper Along Sheet
- Upper Across Sheet

Each achieved sheet allows the option to choose from the preferred Gamma Bracing Systems individual bracing elements as well as the bracing systems listed below. These systems will require the correct references and values to be inputted prior to being used in each of the achieved sheets.

Strictly follow the manufacturer's instructions and ensure the correct Wind and Earthquake values are used. When panel or sheet bracing systems are used the wall length will be required to calculate the bracing values of each bracing element.

- Foundations
- Plywood
- Plasterboard
- User Defined (Customer bracing systems)

The wind and earthquake demand values from the demand sheet are displayed cells at the top of the achieved sheet. Calculate the bracing achieved until the demand value is achieved or exceeded.

For exterior wall bracing lines load in the exterior wall length in meters and ensure the demand value detailed for that bracing line is achieved.

A warning note will be visible if the demand is not achieved.

PRINT SHEET

The Print Sheet automatically stores data from the Main Menu and each of the Along and Across sheets to provide a print version of the bracing calculations. Once the calculations have been completed go to the Print Sheet to print off the information.

House Type	Achieved Sheets to use
Single level on concrete	Upper along/across
Two levels on concrete	Lower along/across & Upper along/across
Single level on timber floor	Subfloor along/across & Upper along/across
Two levels on timber floor	Subfloor along/across, Lower along/across & Upper along/across

Achieved Sheet

Gamma bracing solution V1

Total bracing achieved
Total bracing required

Wind BU's	EQ BU's
0	0
0	0
OK	OK

Upper or single storey bracing walls

This sheet defines bracing walls in the along direction

Line name	Bracing element label	Source of published bracing rating	Bracing wall type	Values achieved					Is bracing element length specified less than minimum?	Check minimum bracing rating in Section 5.4.7 of NZS 3604			
				1 or wall length in metres	Wall Height (metres)	Wall angle in degrees	Wind BU's	EQ BU's		Bracing line capacity BU's	If external wall give length (m)	Requirement for internal walls	Requirement for external walls
A	A1	None	None	1	2.4	0	0	0	OK	0	0		
	A2	None	None	1	2.4	0	0	0	OK				
	A3	None	None	1	2.4	0	0	0	OK				
	A4	None	None	1	2.4	0	0	0	OK				
	A5	None	None	1	2.4	0	0	0	OK				
	A6	None	None	1	2.4	0	0	0	OK				
B	B1	None	None	1	2.4	0	0	0	OK	0	0		
	B2	None	None	1	2.4	0	0	0	OK				
	B3	None	None	1	2.4	0	0	0	OK				
	B4	None	None	1	2.4	0	0	0	OK				
	B5	None	None	1	2.4	0	0	0	OK				
	B6	None	None	1	2.4	0	0	0	OK				
C	C1	None	None	1	2.4	0	0	0	OK	0	0		
	C2	None	None	1	2.4	0	0	0	OK				
	C3	None	None	1	2.4	0	0	0	OK				
	C4	None	None	1	2.4	0	0	0	OK				
	C5	None	None	1	2.4	0	0	0	OK				
	C6	None	None	1	2.4	0	0	0	OK				
D	D1	None	None	1	2.4	0	0	0	OK	0	0		
	D2	None	None	1	2.4	0	0	0	OK				
	D3	None	None	1	2.4	0	0	0	OK				
	D4	None	None	1	2.4	0	0	0	OK				
	D5	None	None	1	2.4	0	0	0	OK				
	D6	None	None	1	2.4	0	0	0	OK				
E	E1	None	None	1	2.4	0	0	0	OK	0	0		
	E2	None	None	1	2.4	0	0	0	OK				
	E3	None	None	1	2.4	0	0	0	OK				
	E4	None	None	1	2.4	0	0	0	OK				
	E5	None	None	1	2.4	0	0	0	OK				
	E6	None	None	1	2.4	0	0	0	OK				
F	F1	None	None	1	2.4	0	0	0	OK	0	0		
	F2	None	None	1	2.4	0	0	0	OK				
	F3	None	None	1	2.4	0	0	0	OK				
	F4	None	None	1	2.4	0	0	0	OK				
	F5	None	None	1	2.4	0	0	0	OK				
	F6	None	None	1	2.4	0	0	0	OK				
G	G1	None	None	1	2.4	0	0	0	OK	0	0		
	G2	None	None	2.5	2.4	0	0	0	OK				
	G3	None	None	1	2.4	0	0	0	OK				
	G4	None	None	1	2.4	0	0	0	OK				
	G5	None	None	1	2.4	0	0	0	OK				
	G6	None	None	1	2.4	0	0	0	OK				



Detailed within Table 3 is the procedure for installing the Gamma Bracing Frames (GBFs). The installation procedure is designed for onsite installations however the GBFs can also be installed at the pre nail framing stage of the construction. Should the GBFs be installed at the pre-nail stage the GBFs will have temporary fasteners installed to hold them in place for the purpose of transportation to the job site. Completion of the installation of the GBFs must be carried out once the pre nail framing has been erected using the same procedures as detailed within Table 3.

TABLE 3

GAMMA INSTALLATION PROCEDURE

1	Once the positions of the Gamma Bracing Frames (GBFs) have been determined from the bracing design remove any cross noggins/dwangs where the GBFs are to be installed. Ensure the inside dimension of the framing provides a suitable fit for the GBFs. A tolerance of +2.0mm and - 0.0mm between the GBF and the timber framing is acceptable. The GBFs need to fit snugly into the framing.
2	For wall heights of 2.7m and 3.0m install the required timber framing members above as detailed.
3	<p>Concrete Floors – External & Internal Walls Where GBFs are located in external walls position the GBFs flush with the inside face of the timber framing to ensure the hold down fastener is away from the edge of the concrete slab (minimum edge distance = 60mm). For internal walls the GBFs can be positioned centrally within the framing.</p> <p>Timber Floors – External & Internal Walls Where GBFs are located in external walls and/or internal walls the GBFs can be positioned anywhere within the framing ensuring the position of the hold down bolt is secured in to solid timber framing.</p> <p>Once the GBFs are positioned mark the positions for the hold down fasteners through the slot in the hold down bracket on to the bottom plate. Remove the GBF or where possible swing the GBF to one side to allow access for drilling the holes for the hold down fasteners. To swing the GBF to one side it is useful to install a single Tek screw fastener into each stud (do not fully tighten these until the GBF is fully installed). Drill the holes for the hold down fasteners.</p>
4	<p>Concrete Floors – Hold Down Anchors Use M12 x 150mm masonry fasteners or M10 x 140mm Masonry Screw in Anchors (Refer Section 15.2 for recommended types of anchor).</p> <p>Timber Floors – Hold Down Anchors Use M12 x 200mm galvanized coach screw to be fastened into solid timber framing (Refer Section 15.2 for recommended types of anchor).</p>
5	Reposition the GBF in between the studs ensuring that the slotted holes in the brackets are aligned with holes in the bottom plate.
6	Install the slotted washer provided and install the hold down anchor and tighten.
7	<p>Each of the hold-down brackets are secured to the GBF framing with a temporary rivet to allow for shipping and have been pre drilled with 8 holes. Using the 12g x 40mm Tek screws fasten each bracket to the timber framing (8 screws per bracket).</p> <p>It is permitted to adjust the brackets up to no greater than 50mm and down by no greater than 39mm to allow for any small deviation in wall framing height. (Refer section 15.8 for further details on height adjustment). Rivet to be removed to enable adjusting.</p>
8	Using 12g x 40mm Tek screws provided fix through the pre punched holes located in the GBFs and into the timber framing.
9	If insulation is to be installed then cut the thermal insulation to fit within the timber framing and Gamma framing members and ensure that insulation protrudes from both sides of the Gamma Bracing Frame (Refer Section 15.3).
10	If interior sheet linings are to be installed, fix as per the manufacturers instructions or as per AS/NZS 2589:2017. Minimum drywall fixing centres to be no greater than 300mm.

5.0 Installation Procedure

- 1** If receiving the framing from the Pre nail manufacture with the Gamma Bracing Frames pre-installed there will be 4, 12g x 40mm Tek screws securing the Gamma Bracing Frame within the timber framing. 2 screws positioned at the upper part of the Gamma Bracing Frame and 1 screw in each of the brackets. Mark the position of the hold down bolt hole on to the timber base plate for each bracket.

When installing Gamma Bracing Frame directly on site position the Gamma Bracing Frame within the timber framing and mark the timber base plate as previously described.

Please note: Observe edge distance requirements for external walls on concrete floors.



- 2** Remove the 2 screws from the brackets only to allow the Gamma Bracing Frame to be swung to one side to allow access for drilling the holes for the hold down bolts.

Drill holes for the hold down bolts for each bracket. Ensure correct size drill bit is used and the correct depth of the hole is achieved.

The temporary rivet can be removed at this point to allow for any minor adjustment of the GBF hold down bracket. Refer Section 14.8 for details on height adjustment.



- 3** Reposition the Gamma Bracing Frame within the framing.



- 4** Install the 2 washers provided, 1 for each bracket.



- 5** Position the hold down bolts in each bracket, 2 per Gamma Bracing Frame (not provided).

Refer to Section 15.2, Table 4 to when choosing the correct hold down bolt.



6 Install the hold down bolts to secure Gamma Bracing Frame to the substrate.



7 Fully tighten the hold down bolts



8 Install eight 12g x 40mm Tek screws in each Bracket. (Provided)



9 Quantity of 8 screws per bracket. (Provided)



10 Install the 12g x 40mm Tek screws to the Gamma Bracing Frame. Pre punched holes are positioned in the up-right sections and the top end cap of the Gamma Bracing Frame.

The Gamma Bracing Frame is now fully installed and providing its structural performance.

The quantities of Tek Screws vary for each system. Refer to the components list for Tek Screw quantities on each system page.



6.0 Gamma Bracing Frame GBF220S

Detailed in the drawing below is the Gamma Bracing Frame GBF220S as it is supplied, along with the GBF hold-down brackets, GBF washers, and Tek Screws. Timber framing and hold-down bolts are not supplied.

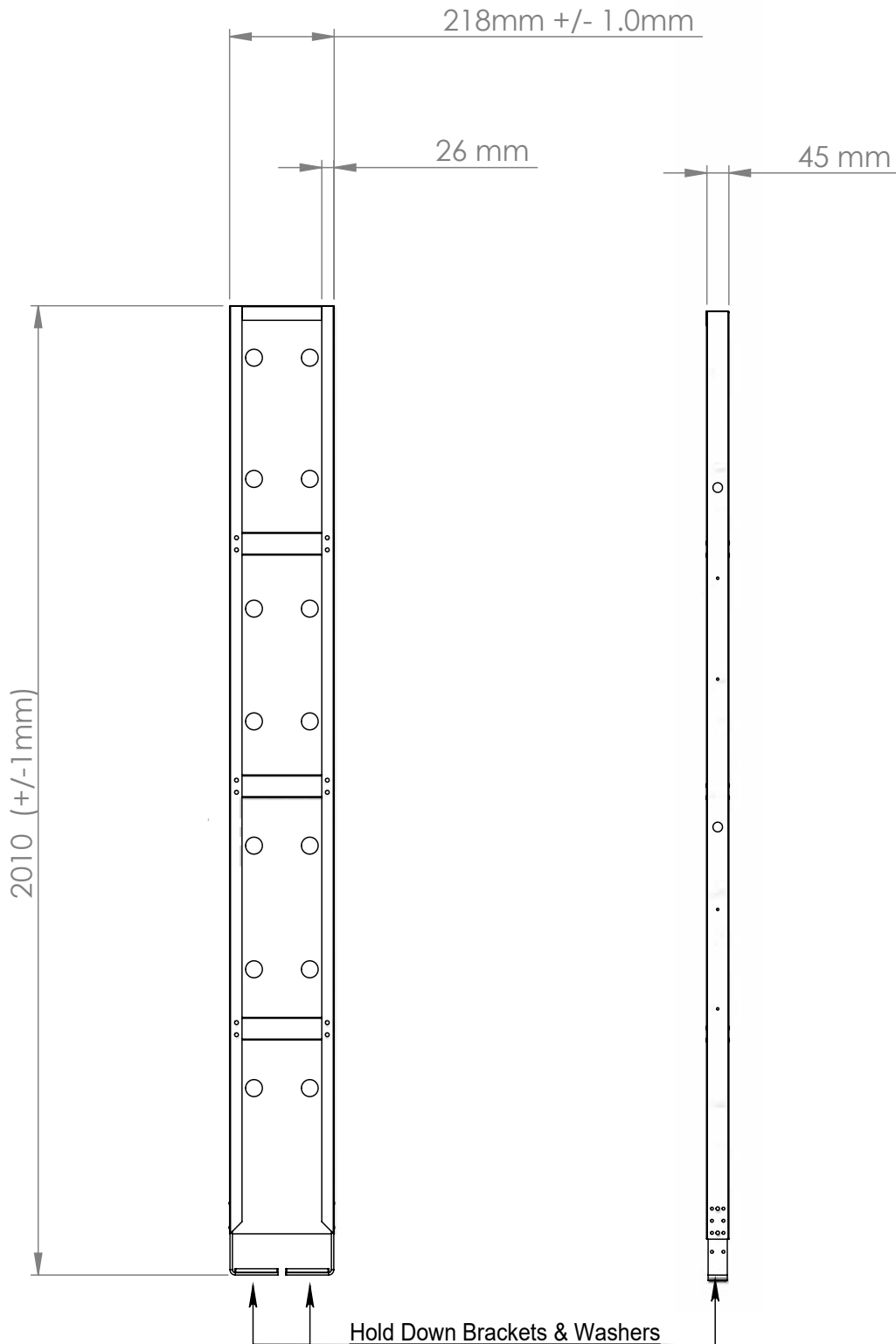

Detailed in the drawing below is the GBF220S as it must be constructed within the timber framing to provide the described wind and earthquake performance values.

Performance - Wind 37BU - Earthquake 44BU

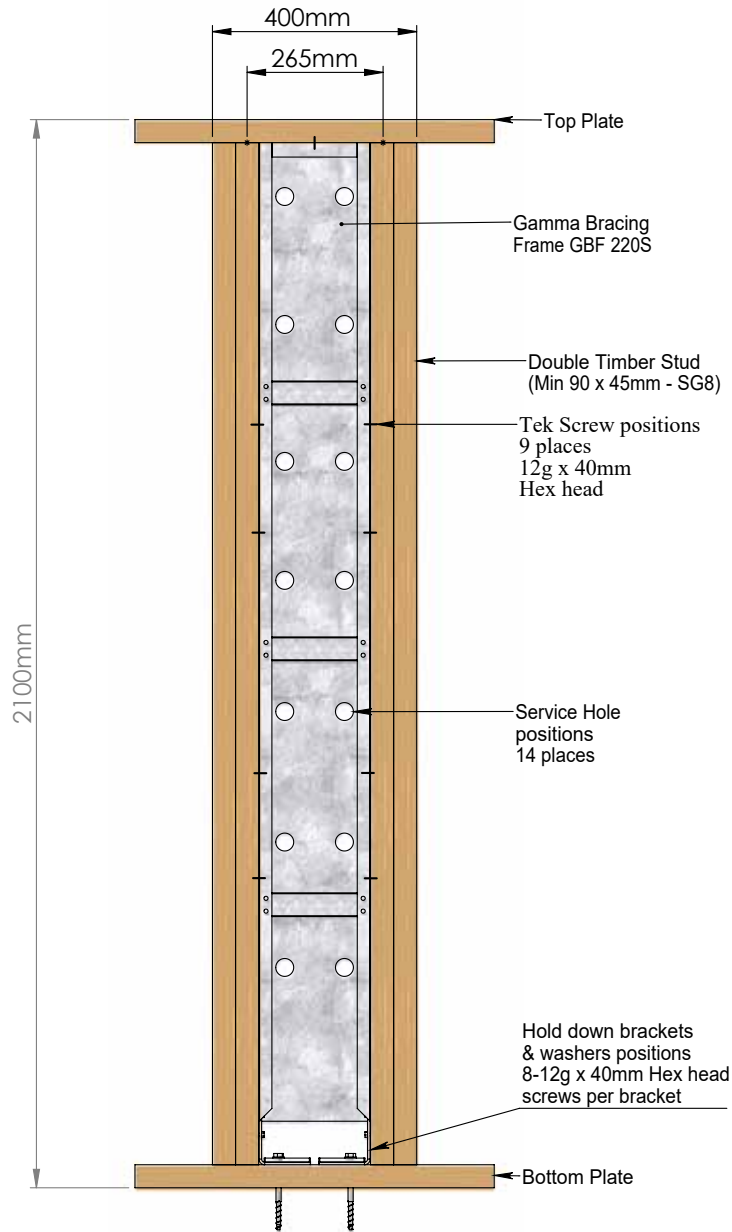

SPECIFICATIONS	
SYSTEM REF	GBF220S
WIND BUs	37
EARTHQUAKE BUs	44
WALL HEIGHT (m)	2.1
WALL LENGTH (m)	0.4

GBF 220S COMPONENTS LIST	
QTY	COMPONENT
1	GBF 220S FRAME
2	GBF HOLD DOWN BRACKETS
2	GBF HOLD DOWN WASHERS
25	12g X 40mm TEK SCREWS
TIMBER FRAMING MIN OF 90 x 45mm SG8 (BY OTHERS)	

7.0 Gamma Bracing Frame GBF220

Detailed in the drawing below is the GBF220 as it is supplied, along with the GBF hold-down brackets, GBF washers, and Tek Screws. Timber framing and hold-down bolts are not supplied.

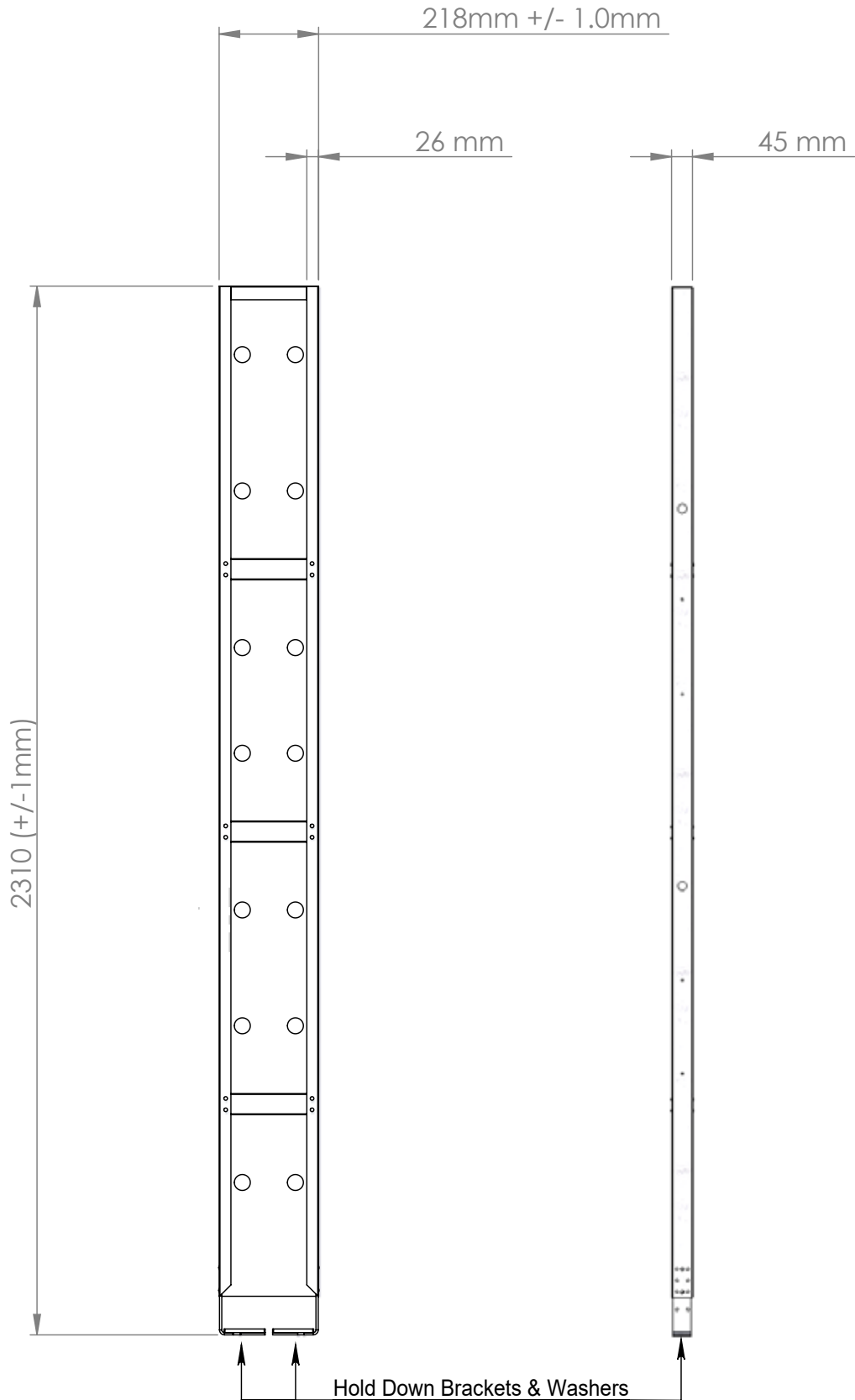

Detailed in the drawing below is the GBF220 as it must be constructed within the timber framing to provide the described wind and earthquake performance values.

Performance - Wind 37BU - Earthquake 44BU

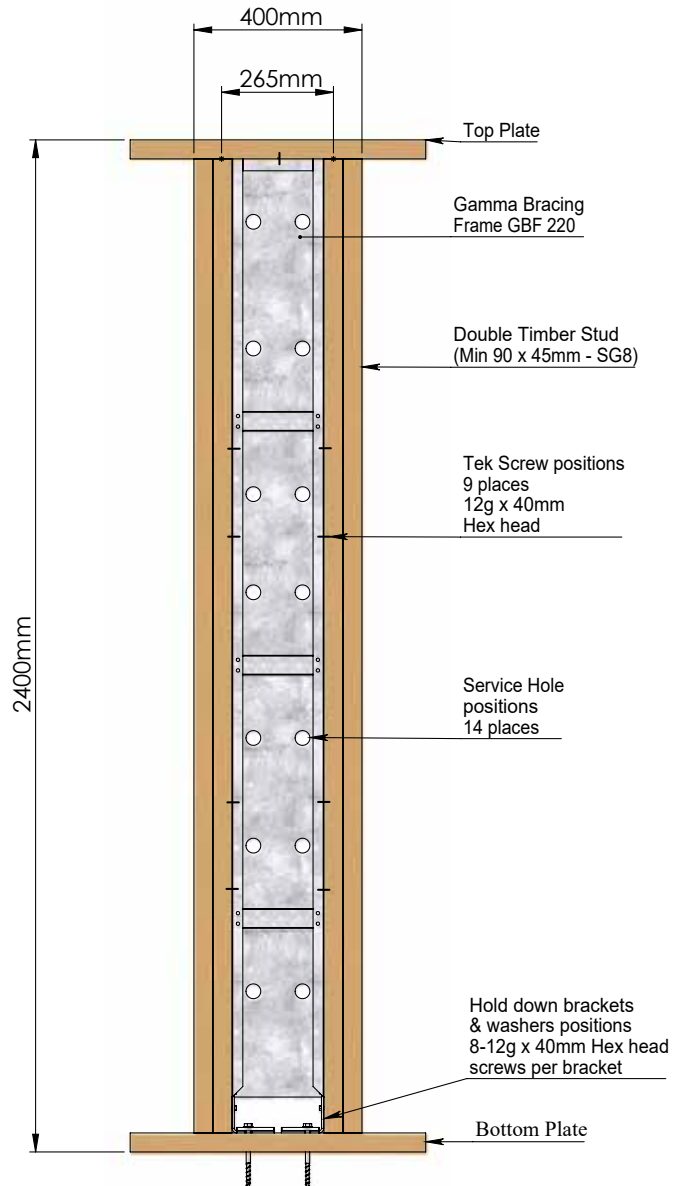

SPECIFICATIONS	
SYSTEM REF	GBF220
WIND BUs	37
EARTHQUAKE BUs	44
WALL HEIGHT (m)	2.4
WALL LENGTH (m)	0.4

GBF 220 COMPONENTS LIST	
QTY	COMPONENT
1	GBF 220 FRAME
2	GBF HOLD DOWN BRACKETS
2	GBF HOLD DOWN WASHERS
25	12g X 40mm TEK SCREWS
TIMBER FRAMING MIN OF 90 x 45mm SG8 (BY OTHERS)	

8.0 Gamma Bracing Frame GBF400S

Detailed in the drawing below is the GBF400S as it is supplied, along with the GBF hold-down brackets, GBF washers, and Tek Screws. Timber framing and hold-down bolts are not supplied.

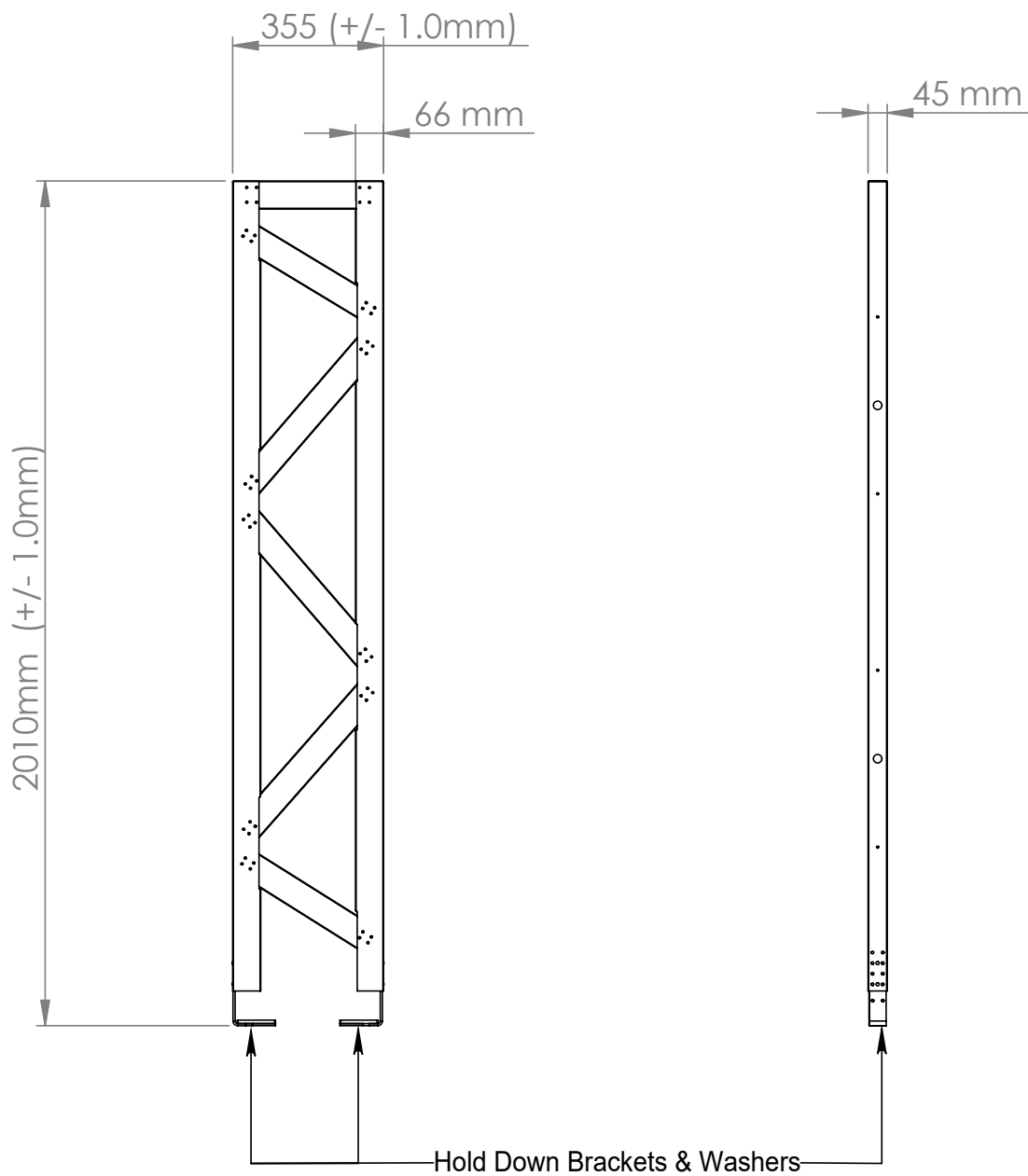

Detailed in the drawing below is the GBF400S as it must be constructed within the timber framing to provide the described wind and earthquake performance values.

Performance - Wind 45BU - Earthquake 55BU

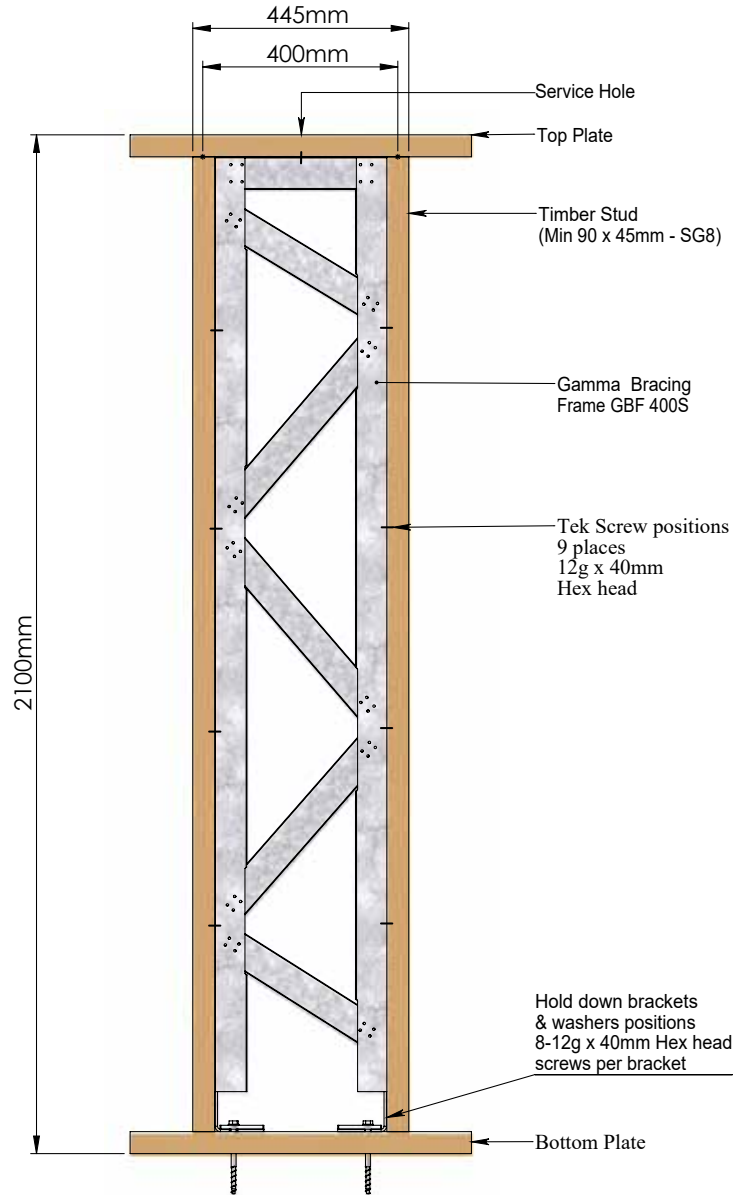

SPECIFICATIONS	
SYSTEM REF	GBF400S
WIND BUs	45
EARTHQUAKE BUs	55
WALL HEIGHT (m)	2.1
WALL LENGTH (m)	0.445

GBF 400S COMPONENTS LIST	
QTY	COMPONENT
1	GBF 400S FRAME
2	GBF HOLD DOWN BRACKETS
2	GBF HOLD DOWN WASHERS
25	12g X 40mm TEK SCREWS
TIMBER FRAMING MIN OF 90 x 45mm SG8 (BY OTHERS)	

9.0 Gamma Bracing Frame GBF400

Detailed in the drawing below is the GBF400 as it is supplied, along with the GBF hold-down brackets, GBF washers, and Tek Screws. Timber framing and hold-down bolts are not supplied.

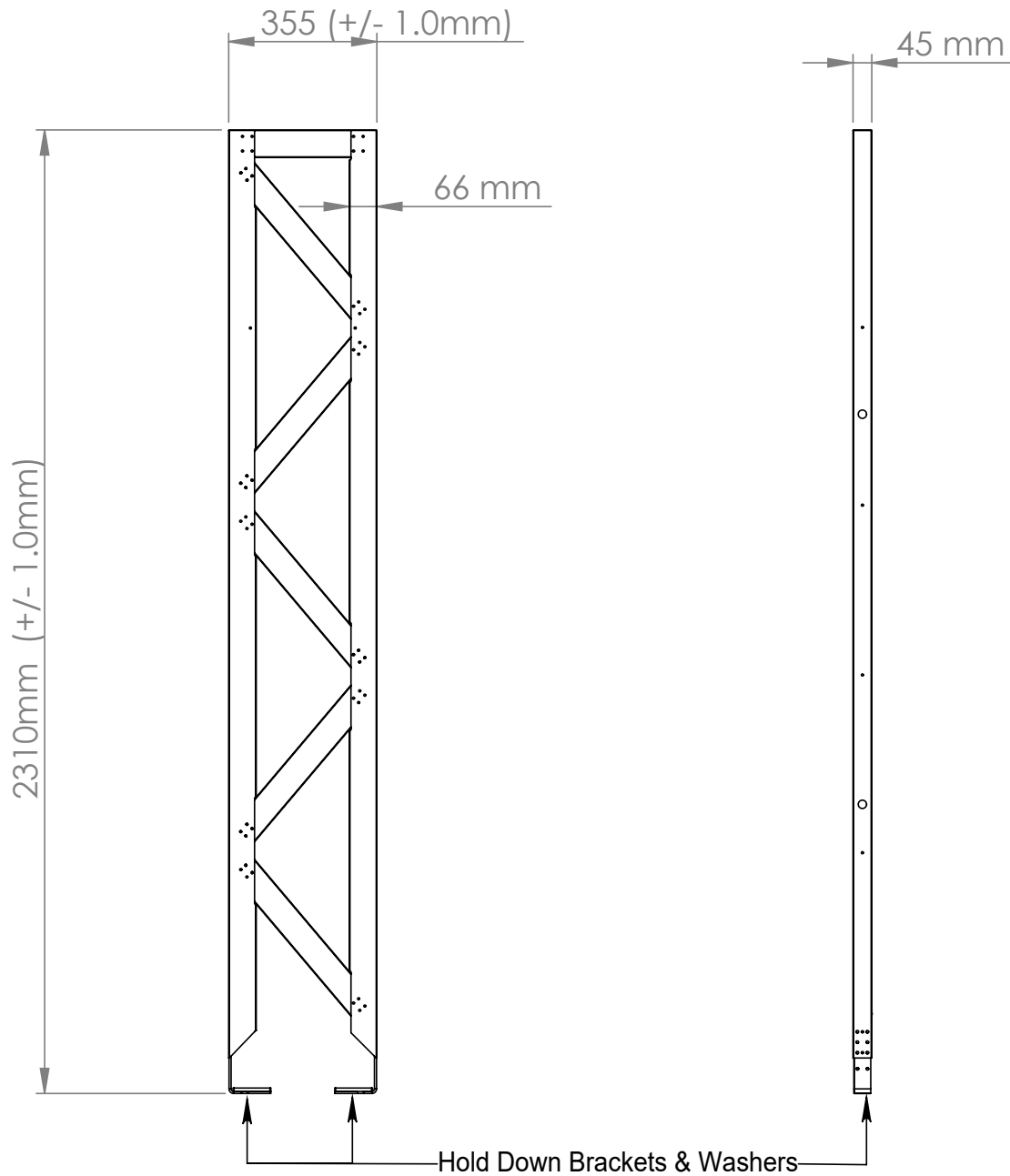

Detailed in the drawing below is the GBF400 as it must be constructed within the timber framing to provide the described wind and earthquake performance values.

Performance - Wind 45BU - Earthquake 55BU

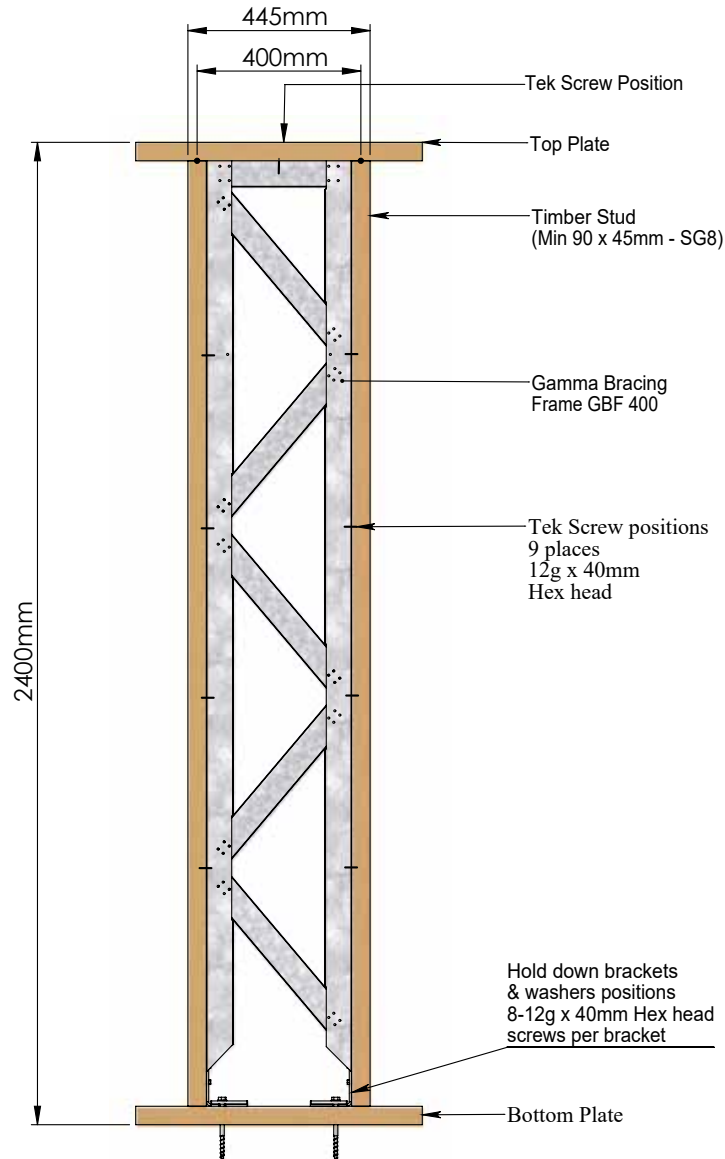

SPECIFICATIONS	
SYSTEM REF	GBF400/2.4
WIND BUs	45
EARTHQUAKE BUs	55
WALL HEIGHT (m)	2.4
WALL LENGTH (m)	0.445

GBF 400/2.4 COMPONENTS LIST	
QTY	COMPONENT
1	GBF 400 FRAME
2	GBF HOLD DOWN BRACKETS
2	GBF HOLD DOWN WASHERS
25	12g X 40mm TEK SCREWS
TIMBER FRAMING MIN OF 90 x 45mm SG8 (BY OTHERS)	

Detailed in the drawing below is the GBF400 as it must be constructed within the timber framing to provide the described wind and earthquake performance values.

Performance - Wind 40BU - Earthquake 47BU

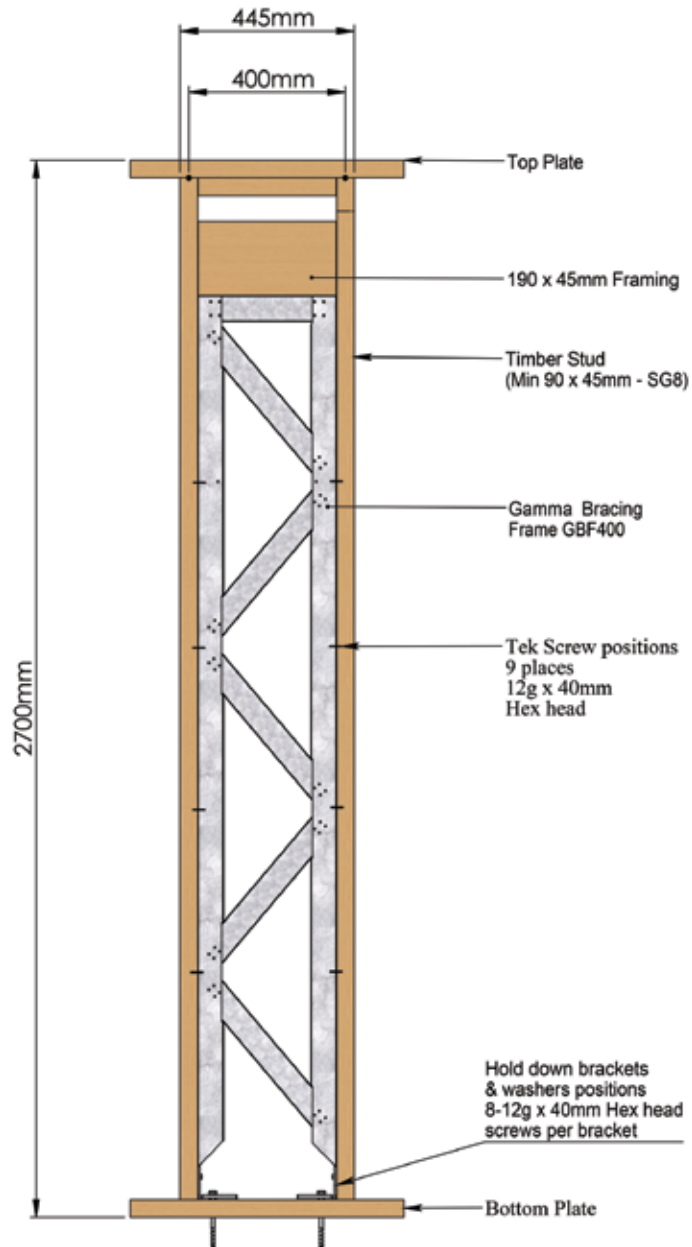

GBF 400/2.7

SPECIFICATIONS	
SYSTEM REF	GBF400/2.7
WIND BUs	40
EARTHQUAKE BUs	47
WALL HEIGHT (m)	2.7
WALL LENGTH (m)	0.4

GBF 400/2.7 COMPONENTS LIST	
QTY	COMPONENT
1	GBF 400 FRAME
2	GBF HOLD DOWN BRACKETS
2	GBF HOLD DOWN WASHERS
25	12g X 40mm TEK SCREWS
TIMBER FRAMING MIN OF 90 x 45mm SG8 (BY OTHERS)	

Detailed in the drawing below is the GBF400 as it must be constructed within the timber framing to provide the described wind and earthquake performance values.

Performance - Wind 35BU - Earthquake 44BU

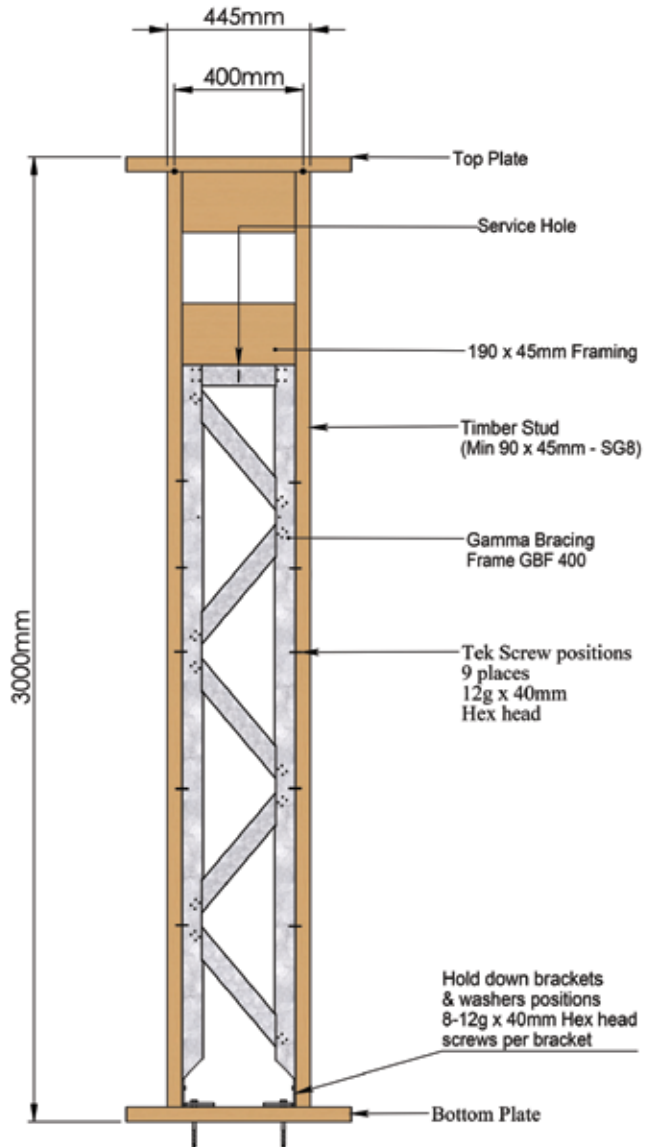

SPECIFICATIONS	
SYSTEM REF	GBF400/3.0
WIND BUs	35
EARTHQUAKE BUs	44
WALL HEIGHT (m)	3.0
WALL LENGTH (m)	0.445

GBF 400/3.0 COMPONENTS LIST	
QTY	COMPONENT
1	GBF 400 FRAME
2	GBF HOLD DOWN BRACKETS
2	GBF HOLD DOWN WASHERS
25	12g X 40mm TEK SCREWS
TIMBER FRAMING MIN OF 90 x 45mm SG8 (BY OTHERS)	

Detailed in the drawing below is the GBF535S as it must be constructed within the timber framing to provide the described wind and earthquake performance values.

Performance - Wind 69BU - Earthquake 75BU

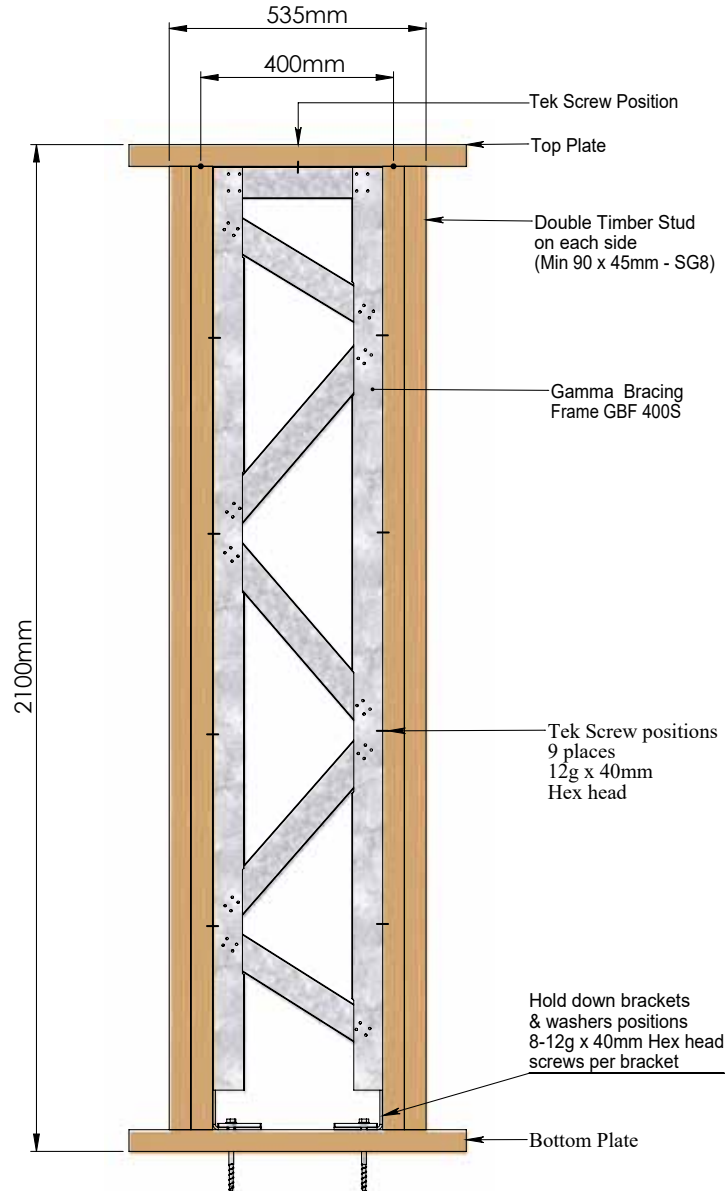

SPECIFICATIONS	
SYSTEM REF	GBF535S
WIND BUs	69
EARTHQUAKE BUs	75
WALL HEIGHT (m)	2.1
WALL LENGTH (m)	0.535

GBF 535S COMPONENTS LIST	
QTY	COMPONENT
1	GBF 400S FRAME
2	GBF HOLD DOWN BRACKETS
2	GBF HOLD DOWN WASHERS
25	12g X 40mm TEK SCREWS
TIMBER FRAMING MIN OF 90 x 45mm SG8 (BY OTHERS)	

Detailed in the drawing below is the GBF535 as it must be constructed within the timber framing to provide the described wind and earthquake performance values.

Performance - Wind 69BU - Earthquake 75BU

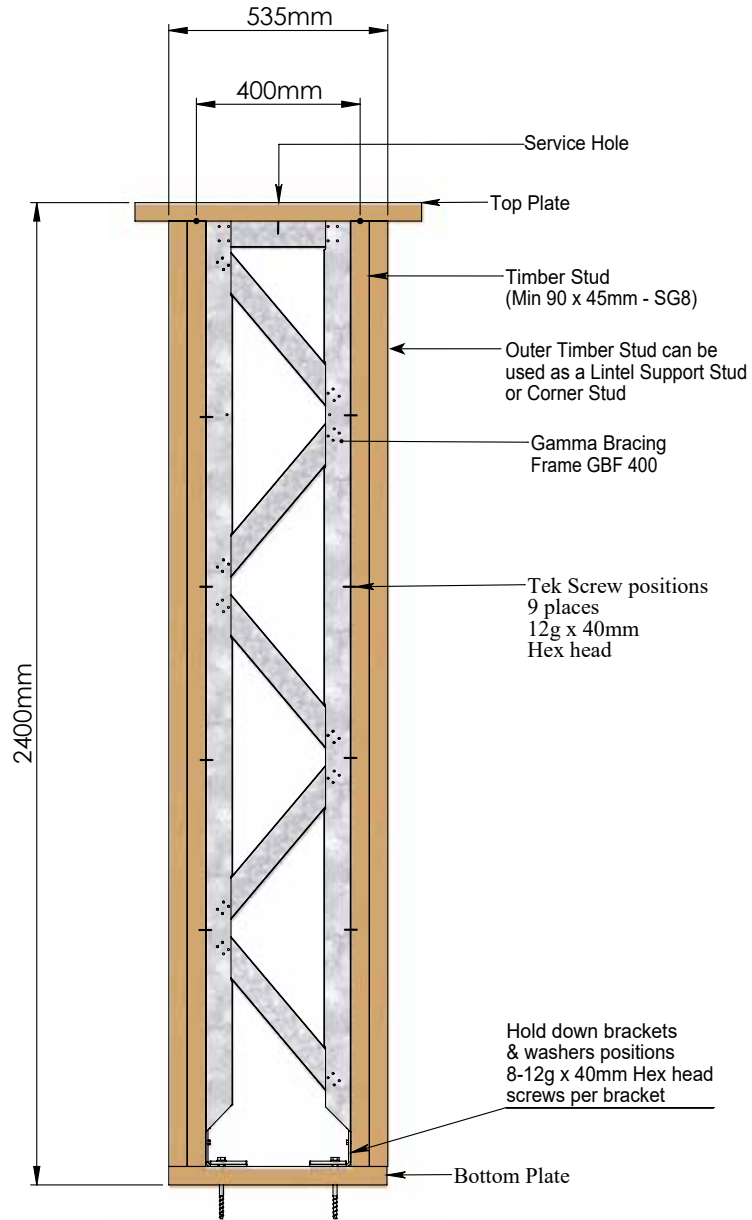

SPECIFICATIONS	
SYSTEM REF	GBF535/2.4
WIND BUs	69
EARTHQUAKE BUs	75
WALL HEIGHT (m)	2.4
WALL LENGTH (m)	0.535

GBF 535/2.4 COMPONENTS LIST	
QTY	COMPONENT
1	GBF 400 FRAME
2	GBF HOLD DOWN BRACKETS
2	GBF HOLD DOWN WASHERS
25	12g X 40mm TEK SCREWS
TIMBER FRAMING MIN OF 90 x 45mm SG8 (BY OTHERS)	

10.2 Gamma Bracing System Construction GBF535/2.7

Detailed in the drawing below is the GBF535 as it must be constructed within the timber framing to provide the described wind and earthquake performance values.

Performance - Wind 61BU - Earthquake 67BU

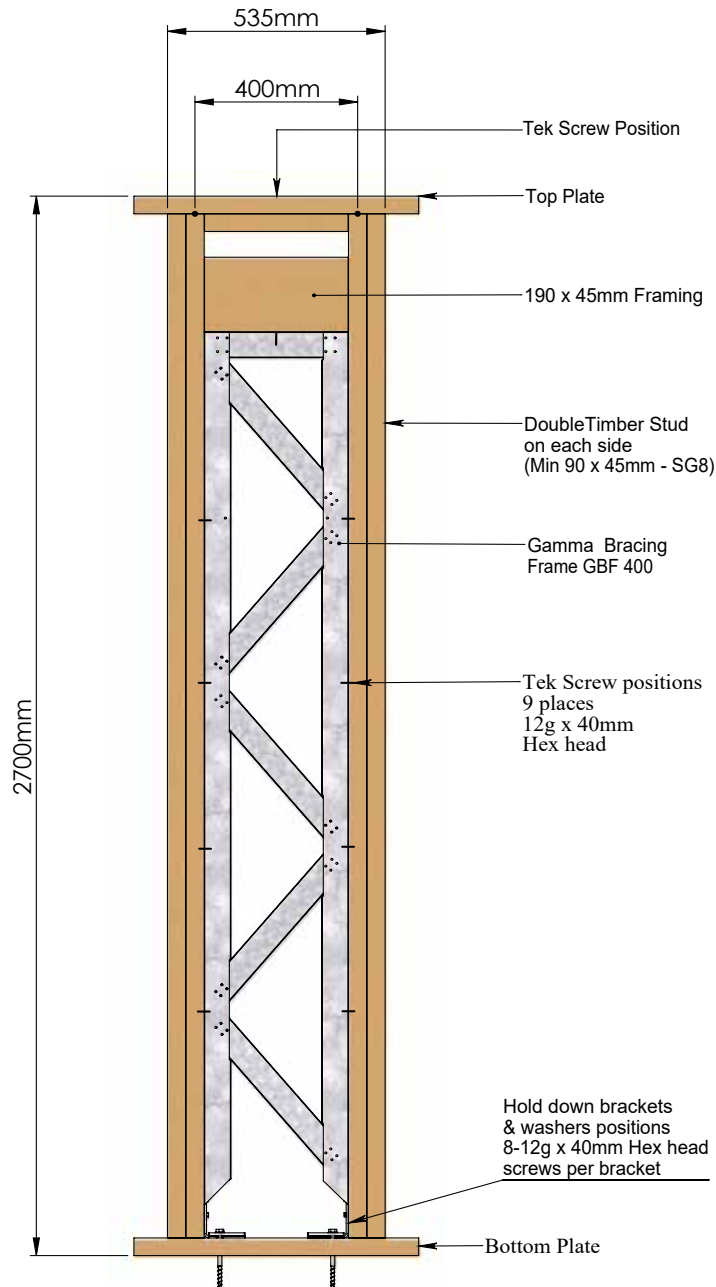

SPECIFICATIONS	
SYSTEM REF	GBF535/2.7
WIND BUs	61
EARTHQUAKE BUs	67
WALL HEIGHT (m)	2.7
WALL LENGTH (m)	0.4

GBF 535/2.7 COMPONENTS LIST	
QTY	COMPONENT
1	GBF 400 FRAME
2	GBF HOLD DOWN BRACKETS
2	GBF HOLD DOWN WASHERS
25	12g X 40mm TEK SCREWS
TIMBER FRAMING MIN OF 90 x 45mm SG8 (BY OTHERS)	

Detailed in the drawing below is the GBF535 as it must be constructed within the timber framing to provide the described wind and earthquake performance values.

Performance - Wind 55BU - Earthquake 60BU

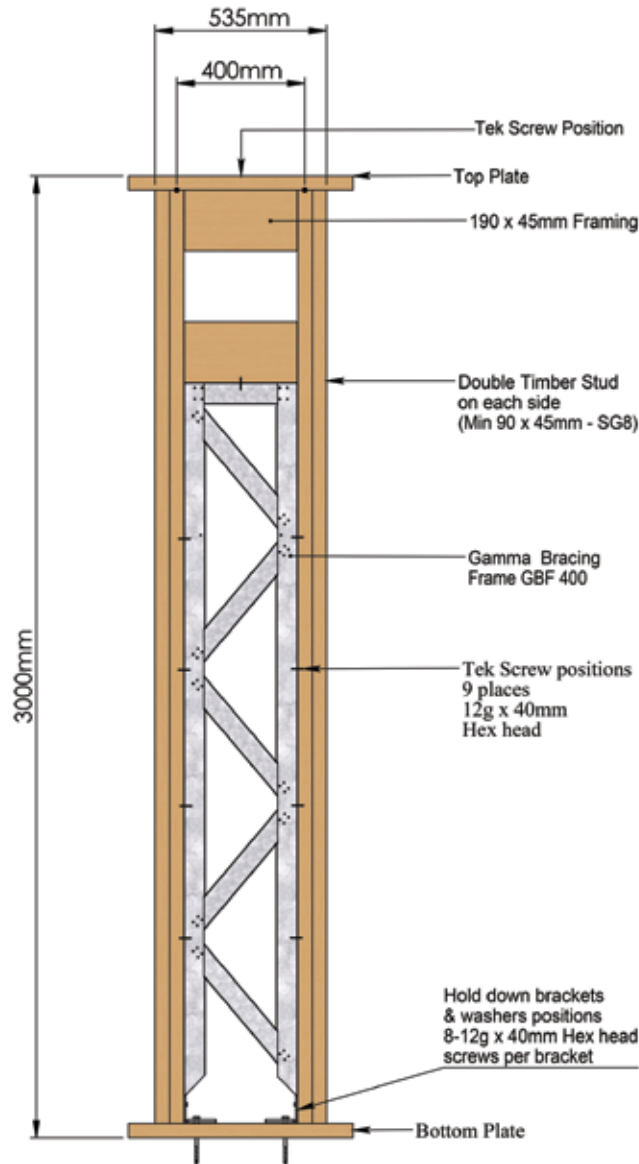

SPECIFICATIONS	
SYSTEM REF	GBF535/3.0
WIND BUs	55
EARTHQUAKE BUs	60
WALL HEIGHT (m)	3.0
WALL LENGTH (m)	0.535

GBF 535/3.0 COMPONENTS LIST	
QTY	COMPONENT
1	GBF 400 FRAME
2	GBF HOLD DOWN BRACKETS
2	GBF HOLD DOWN WASHERS
25	12g X 40mm TEK SCREWS
TIMBER FRAMING MIN OF 90 x 45mm SG8 (BY OTHERS)	

11.0 Gamma Bracing Frame GBF600S

Detailed in the drawing below is the GBF600S as it is supplied, along with the GBF hold-down brackets, GBF Washers and TEK Screws. Timber framing and hold-down bolts are not supplied.

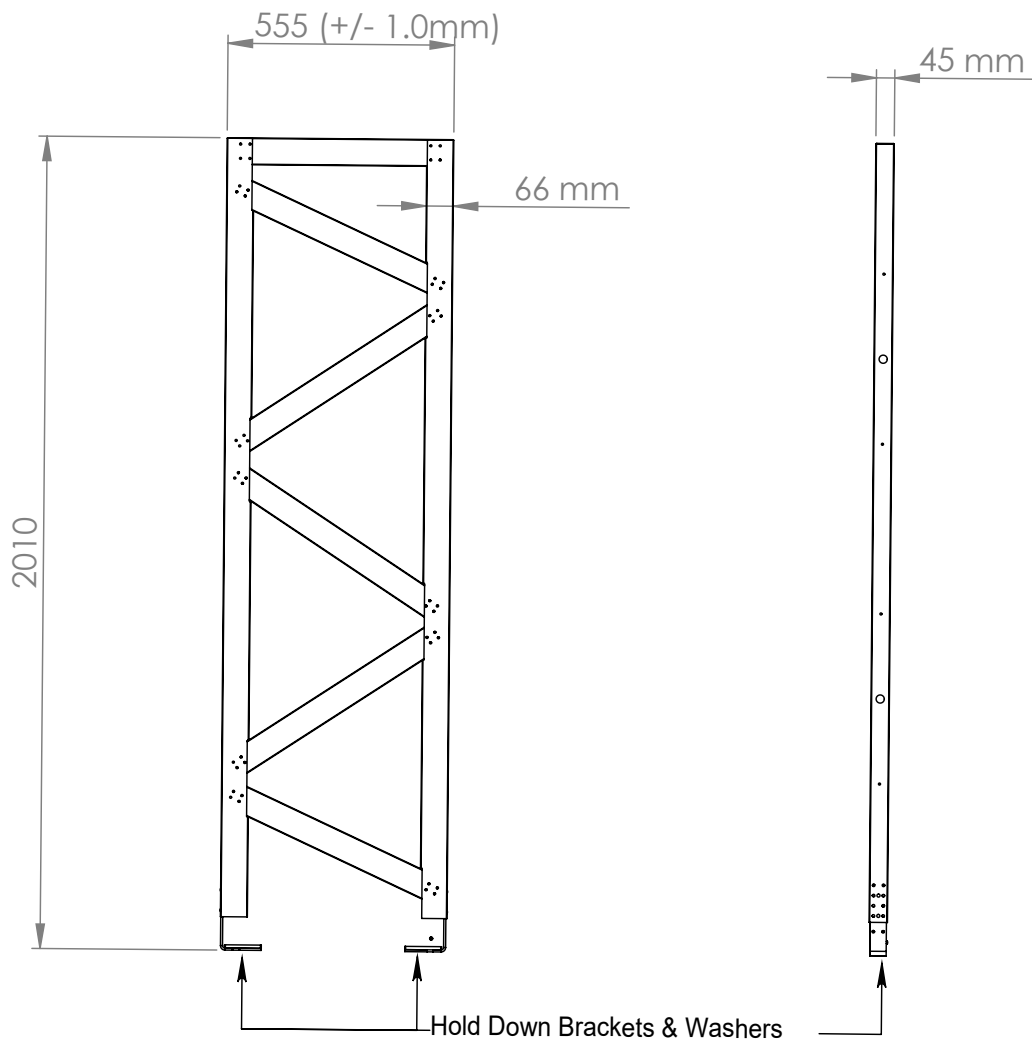

Detailed in the drawing below is the GBF600S as it must be constructed within the timber framing to provide the described wind and earthquake performance values.

Performance - Wind 84BU - Earthquake 90BU

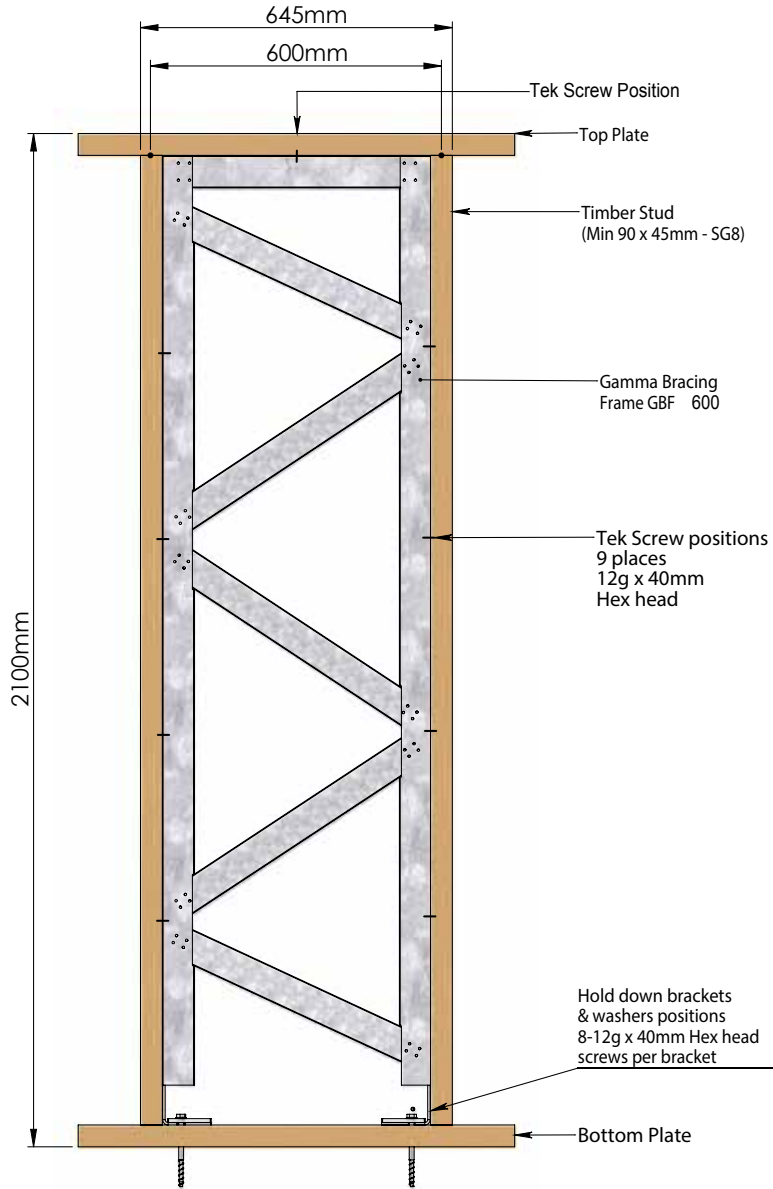

SPECIFICATIONS	
SYSTEM REF	GBF600S
WIND BUs	84
EARTHQUAKE BUs	90
WALL HEIGHT (m)	2.1
WALL LENGTH (m)	0.690

GBF 600S COMPONENTS LIST	
QTY	COMPONENT
1	GBF 600S FRAME
2	GBF HOLD DOWN BRACKETS
2	GBF HOLD DOWN WASHERS
25	12g X 40mm TEK SCREWS
TIMBER FRAMING MIN OF 90 x 45mm SG8 (BY OTHERS)	

12.0 Gamma Bracing Frame GBF600/2.4

Detailed in the drawing below is the GBF600 as it is supplied, along with the GBF hold-down brackets, GBF Washers and TEK Screws. Timber framing and hold-down bolts are not supplied.

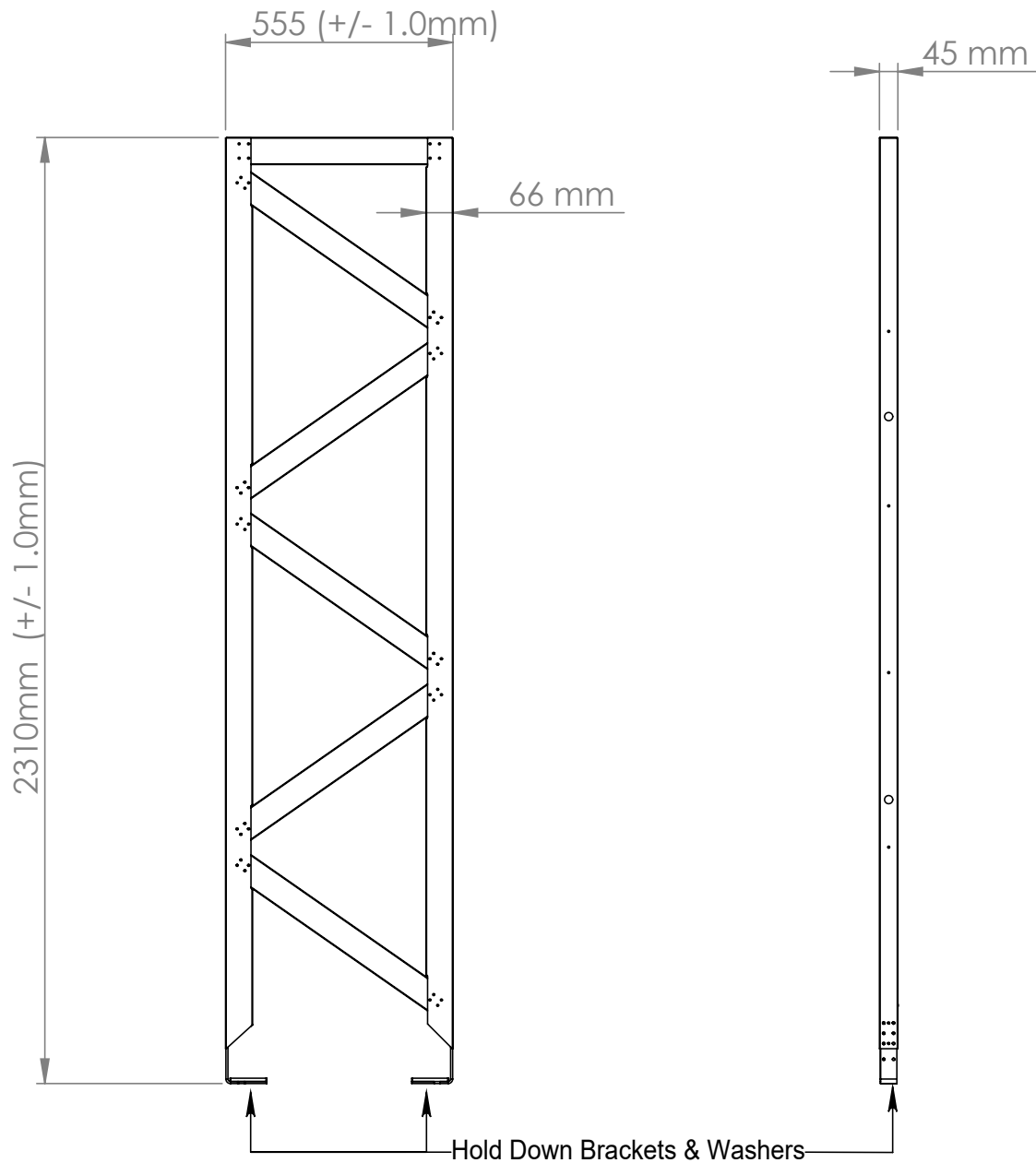

Detailed in the drawing below is the GBF600 as it must be constructed within the timber framing to provide the described wind and earthquake performance values.

Performance - Wind 84BU - Earthquake 90BU

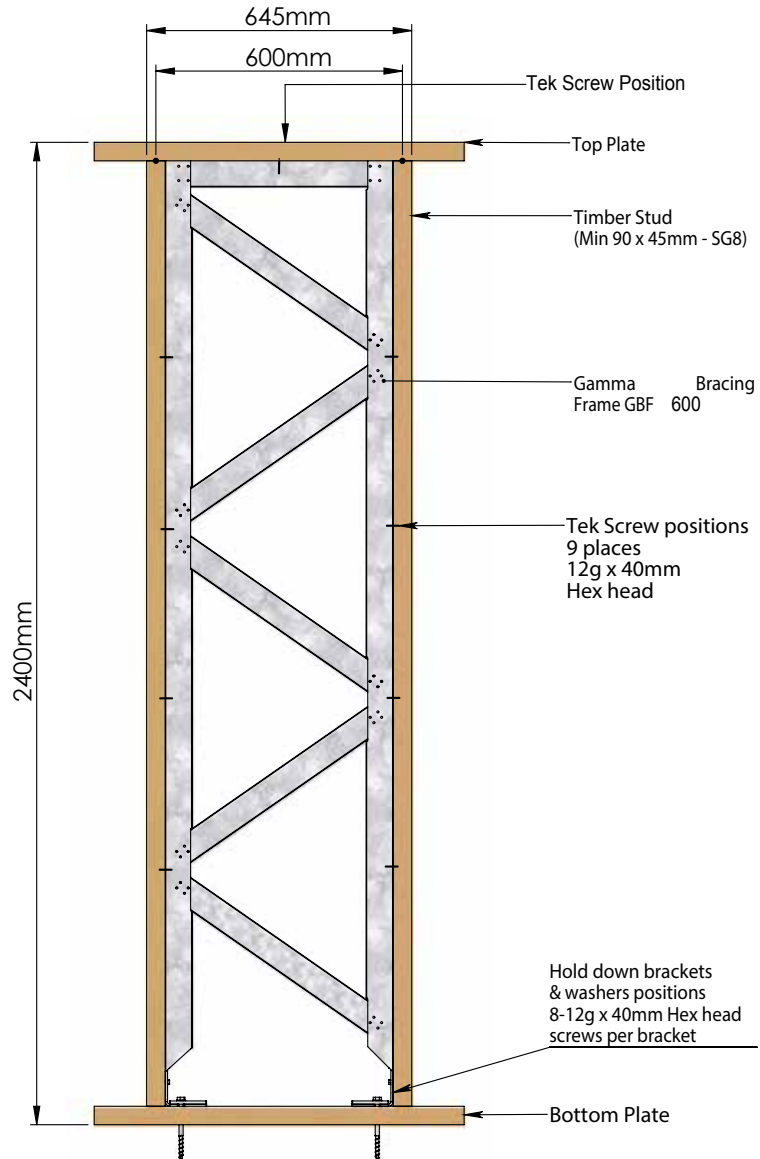

SPECIFICATIONS	
SYSTEM REF	GBF600/2.4
WIND BUs	84
EARTHQUAKE BUs	90
WALL HEIGHT (m)	2.4
WALL LENGTH (m)	0.690

GBF 600/2.4 COMPONENTS LIST	
QTY	COMPONENT
1	GBF 600 FRAME
2	GBF HOLD DOWN BRACKETS
2	GBF HOLD DOWN WASHERS
25	12g X 40mm TEK SCREWS
TIMBER FRAMING MIN OF 90 x 45mm SG8 (BY OTHERS)	

12.2 Gamma Bracing System Construction GBF600/2.7

Detailed in the drawing below is the GBF600 as it must be constructed within the timber framing to provide the described wind and earthquake performance values.

Performance - Wind 70BU - Earthquake 70BU

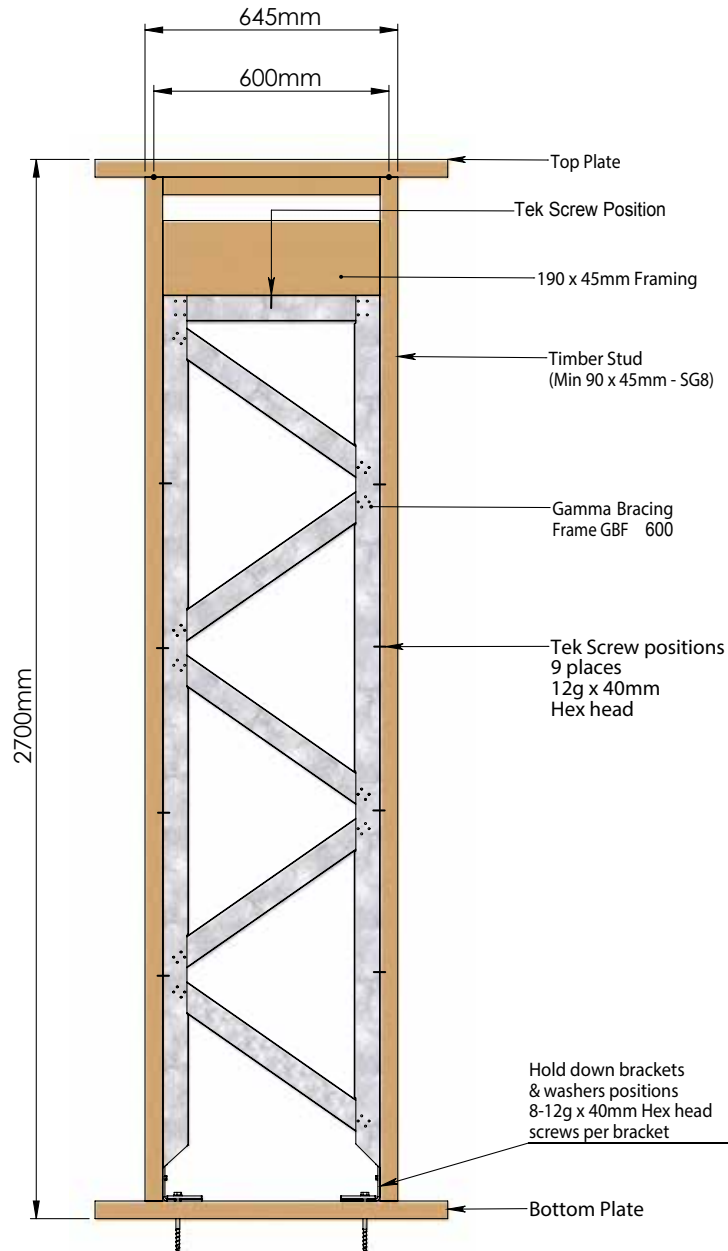

SPECIFICATIONS	
SYSTEM REF	GBF600/2.7
WIND BUs	70
EARTHQUAKE BUs	70
WALL HEIGHT (m)	2.7
WALL LENGTH (m)	0.690

GBF 600/2.7 COMPONENTS LIST	
QTY	COMPONENT
1	GBF 600 FRAME
2	GBF HOLD DOWN BRACKETS
2	GBF HOLD DOWN WASHERS
25	12g X 40mm TEK SCREWS
TIMBER FRAMING MIN OF 90 x 45mm SG8 (BY OTHERS)	

Detailed in the drawing below is the GBF600 as it must be constructed within the timber framing to provide the described wind and earthquake performance values.

Performance - Wind 55BU - Earthquake 60BU

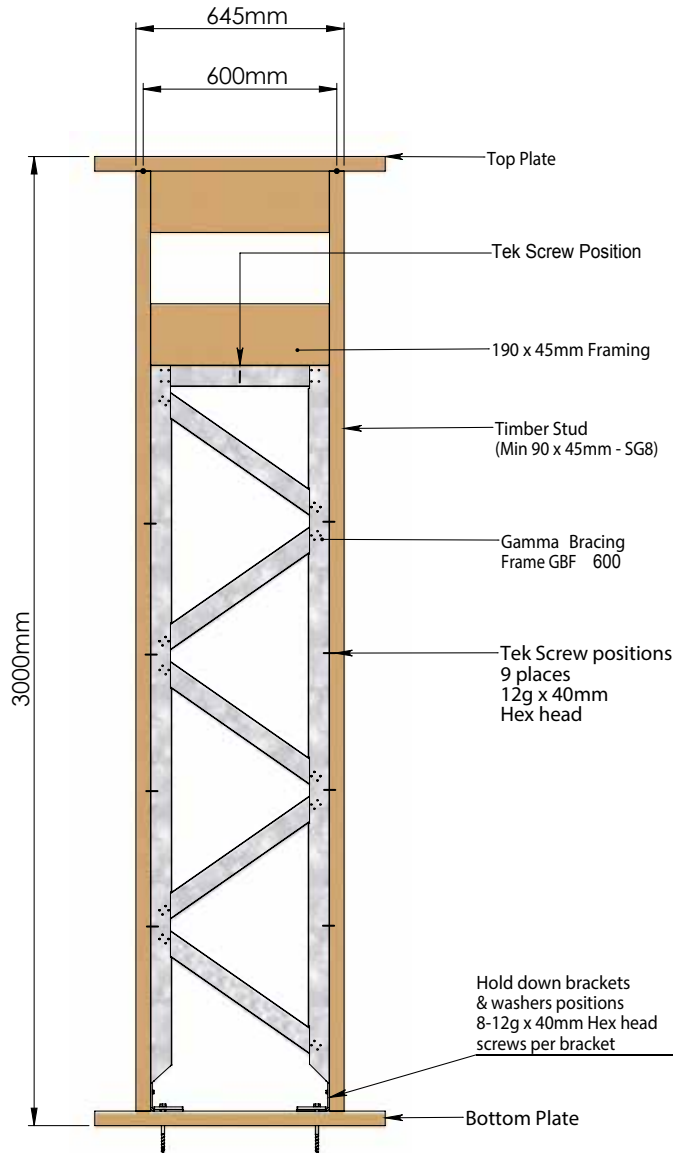

SPECIFICATIONS	
SYSTEM REF	GBF600/3.0
WIND BUs	55
EARTHQUAKE BUs	60
WALL HEIGHT (m)	3.0
WALL LENGTH (m)	0.690

GBF 600/3.0 COMPONENTS LIST	
QTY	COMPONENT
1	GBF 600 FRAME
2	GBF HOLD DOWN BRACKETS
2	GBF HOLD DOWN WASHERS
25	12g X 40mm TEK SCREWS
TIMBER FRAMING MIN OF 90 x 45mm SG8 (BY OTHERS)	

GAMMA PORTAL (6.0 X 2.4m) INTERNAL SIDE SHOWN PERFORMANCE: WIND =124 BU's / EARTHQUAKE = 137 BU's

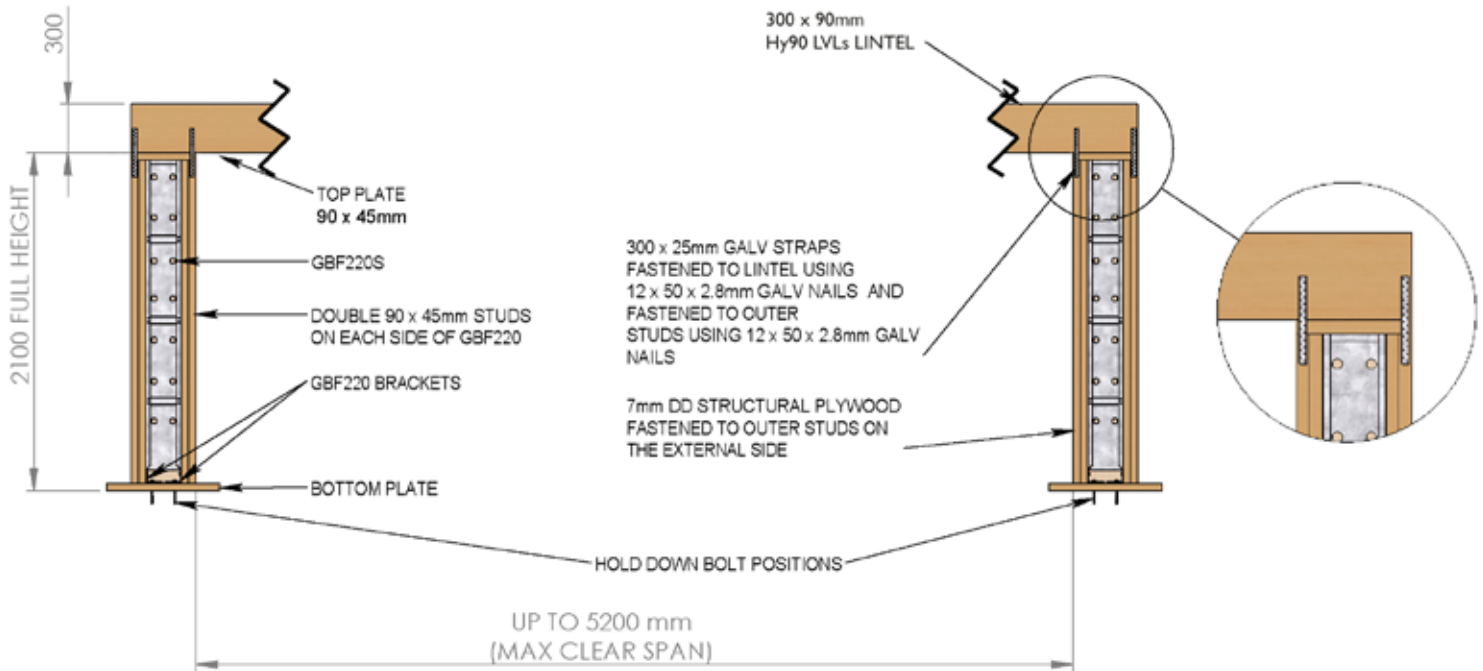

GAMMA PORTAL (6.0 X 2.4m) EXTERNAL SIDE SHOWN PERFORMANCE: WIND =124 BU's / EARTHQUAKE = 137 BU's

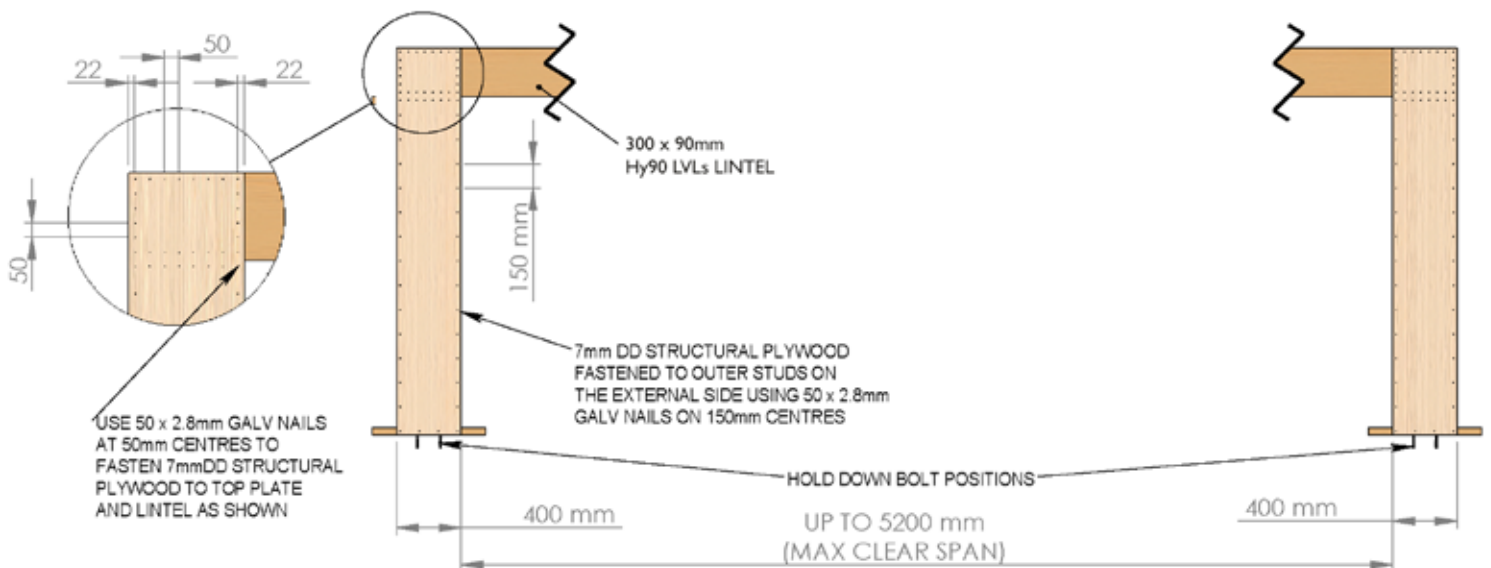

The 300 x 90mm Hy90 LVL lintel may be replaced with an alternative timber or flitch beam of equivalent or superior structural capacity. Any substitution must be verified against the manufacturer's technical specifications to ensure all performance criteria are satisfied.

GBPF/2.4 COMPONENTS LIST	
QTY	COMPONENTS
2	GBF220S
4	GBF HOLD-DOWN BRACKETS
4	GBF HOLD-DOWN WASHERS
50	12g X 40mm TEK SCREWS
TIMBER FRAMING MIN OF 90 X 45mm AND 300 X 90 (BY OTHERS)	

**GAMMA PORTAL (6.0 X 2.7m) INTERNAL SIDE SHOWN
PERFORMANCE: WIND = 110 BU's / EARTHQUAKE = 122 BU's**

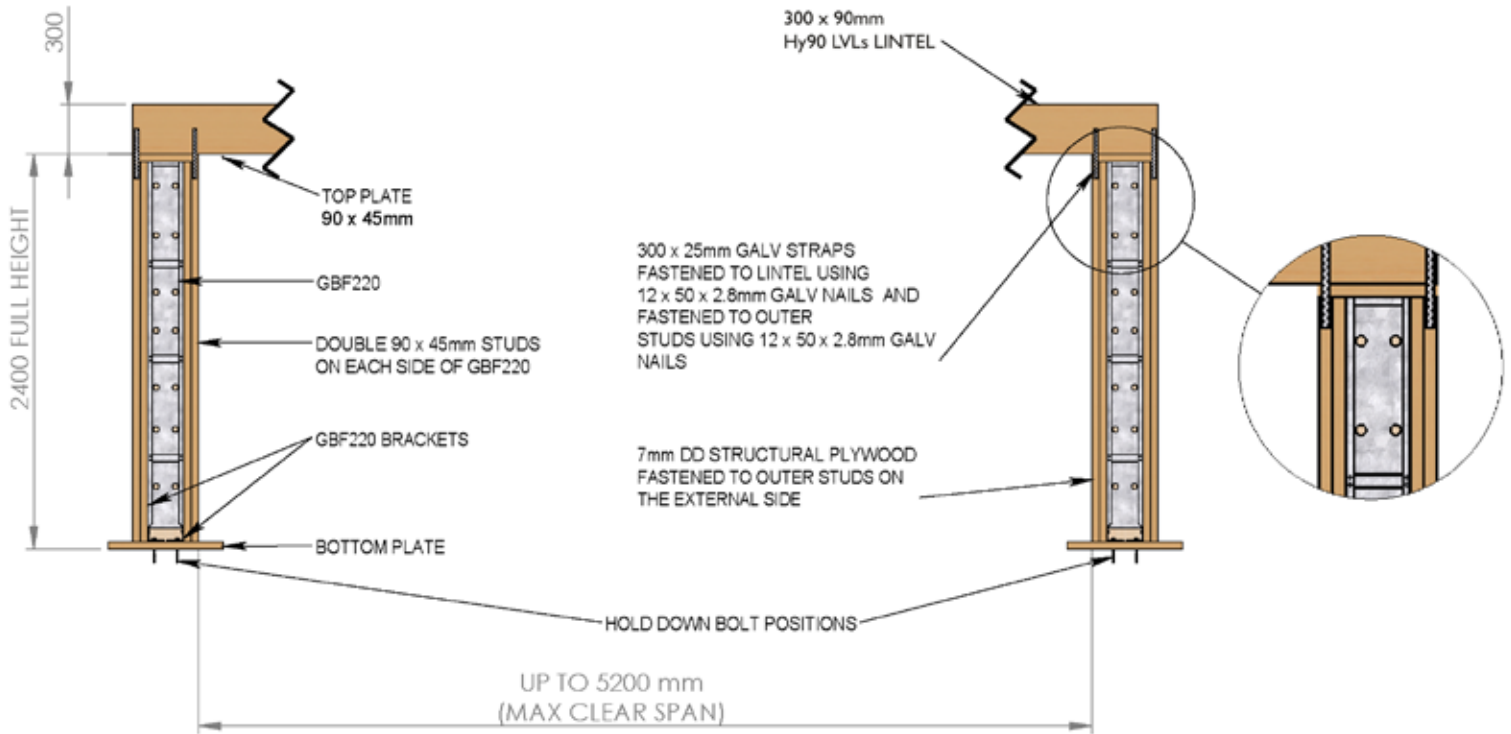

**GAMMA PORTAL (6.0 X 2.7m) EXTERNAL SIDE SHOWN
PERFORMANCE: WIND = 110 BU's / EARTHQUAKE = 122 BU's**

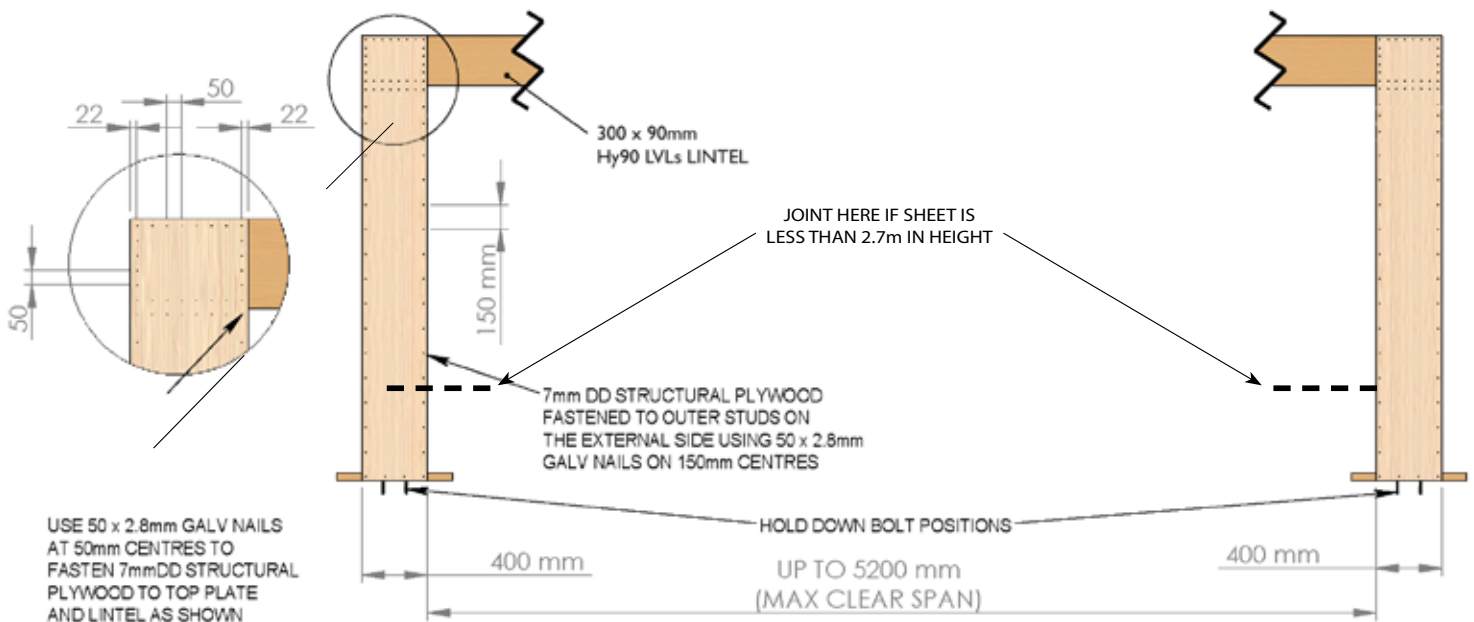

The 300 x 90mm Hy90 LVL lintel may be replaced with an alternative timber or flitch beam of equivalent or superior structural capacity. Any substitution must be verified against the manufacturer's technical specifications to ensure all performance criteria are satisfied.

GBPF/2.7 COMPONENTS LIST	
QTY	COMPONENTS
2	GBF220
4	GBF HOLD-DOWN BRACKETS
4	GBF HOLD-DOWN WASHERS
50	12g X 40mm TEK SCREWS
TIMBER FRAMING MIN OF 90 X 45mm AND 300 X 90 (BY OTHERS)	

Detailed in the drawing below is the GBF600 Twin System as it must be constructed to provide the described Wind and Earthquake performance values.

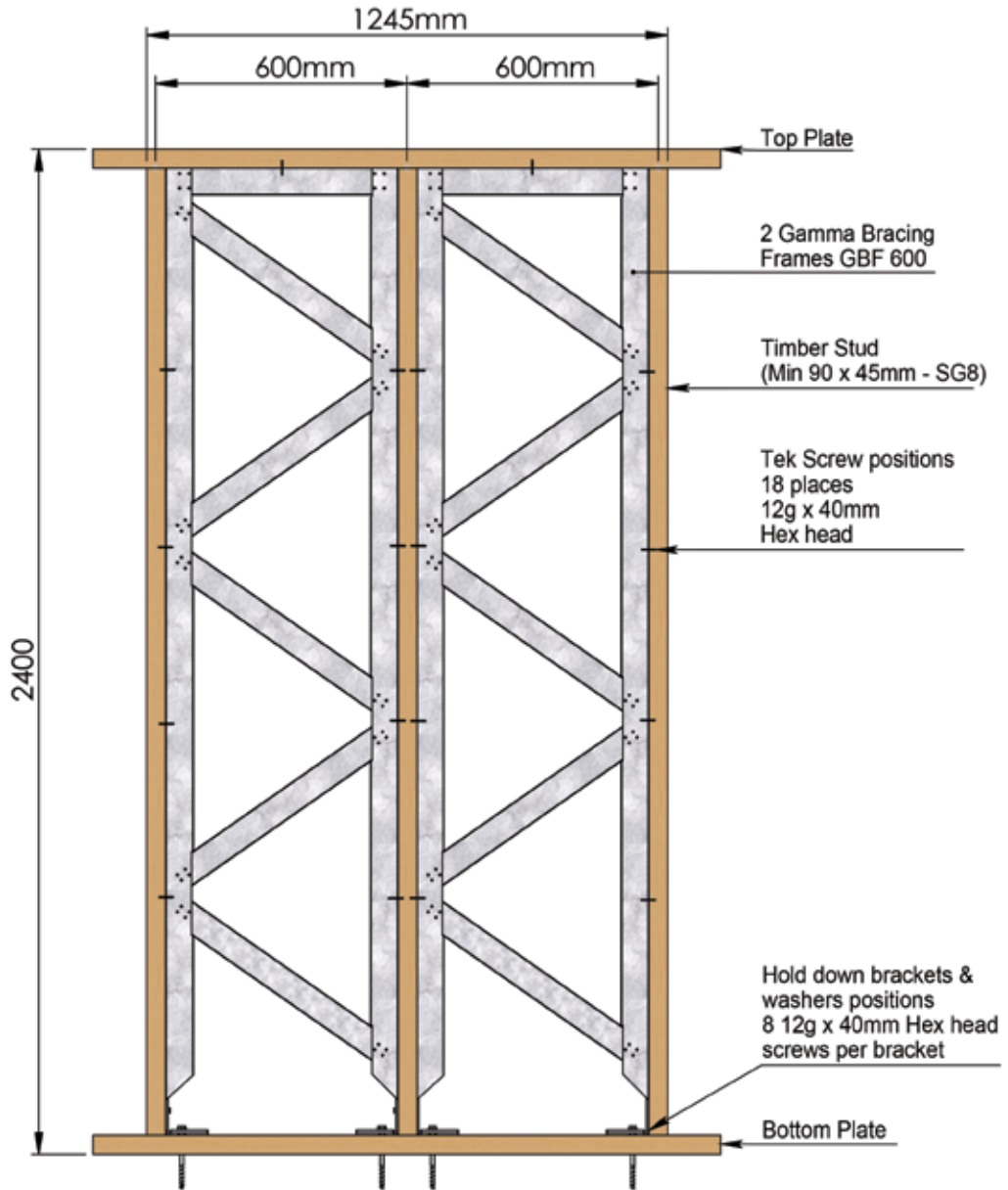

SPECIFICATIONS	
SYSTEM REF	GBF600/2.4 TWIN
WIND BUs	168
EARTHQUAKE BUs	180
WALL HEIGHT (m)	2.4
WALL LENGTH (m)	1.245

GBF 600/2.4 TWIN COMPONENTS LIST	
QTY	COMPONENT
2	GBF 600 FRAMES
4	GBF HOLD DOWN BRACKETS
4	GBF HOLD DOWN WASHERS
50	12g X 40mm TEK SCREWS
TIMBER FRAMING MIN OF 90 x 45mm SG8 (BY OTHERS)	

Detailed in the drawing below is the GBF600 Twin System as it must be constructed to provide the described Wind and Earthquake performance values.

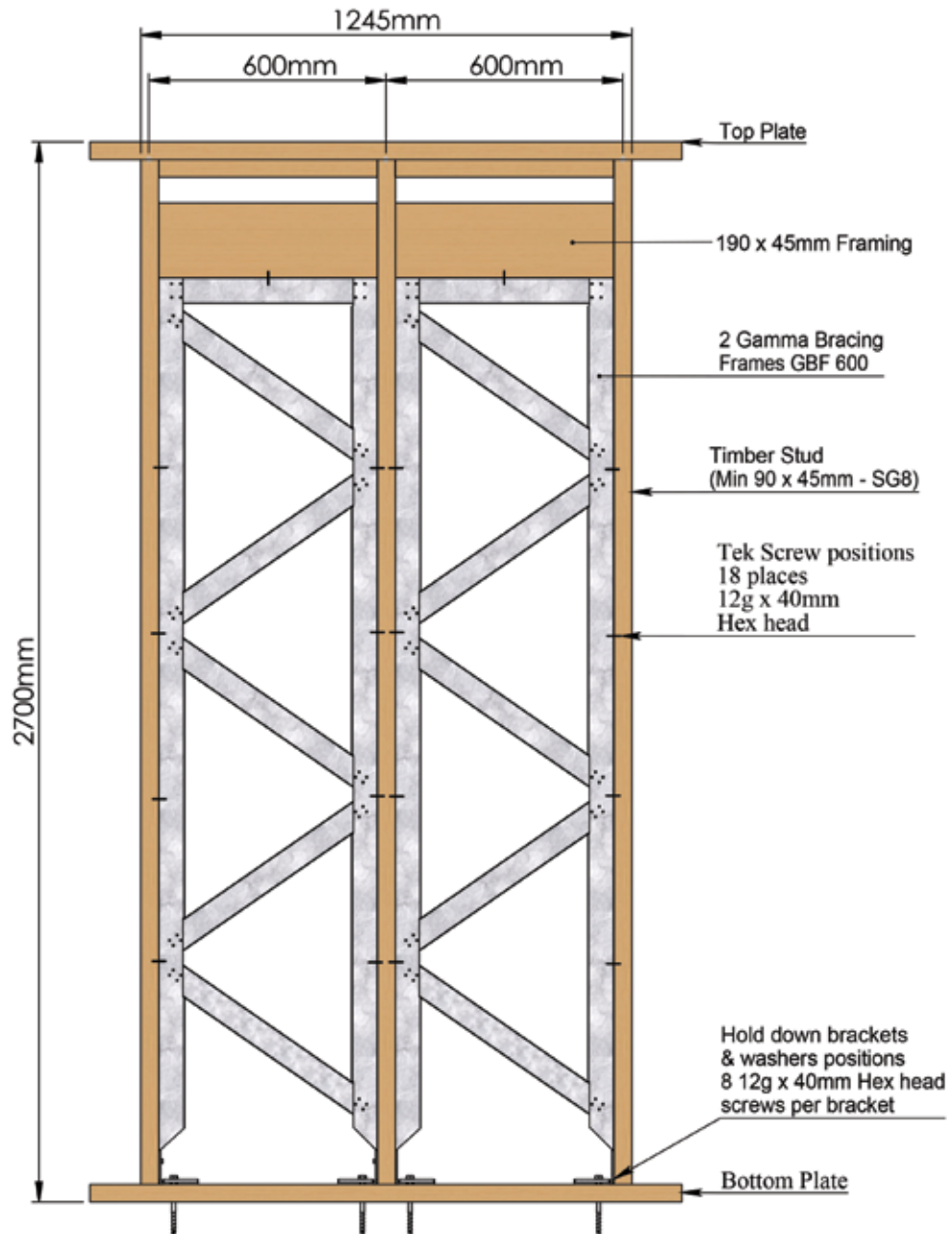

SPECIFICATIONS	
SYSTEM REF	GBF600/2.7 TWIN
WIND BUs	140
EARTHQUAKE BUs	140
WALL HEIGHT (m)	2.7
WALL LENGTH (m)	1.245

GBF 600/2.7 TWIN COMPONENTS LIST	
QTY	COMPONENT
2	GBF 600 FRAMES
4	GBF HOLD DOWN BRACKETS
4	GBF HOLD DOWN WASHERS
50	12g X 40mm TEK SCREWS
TIMBER FRAMING MIN OF 90 x 45mm SG8 (BY OTHERS)	

Detailed in the drawing below is the GBF600 Twin System as it must be constructed to provide the described Wind and Earthquake performance values

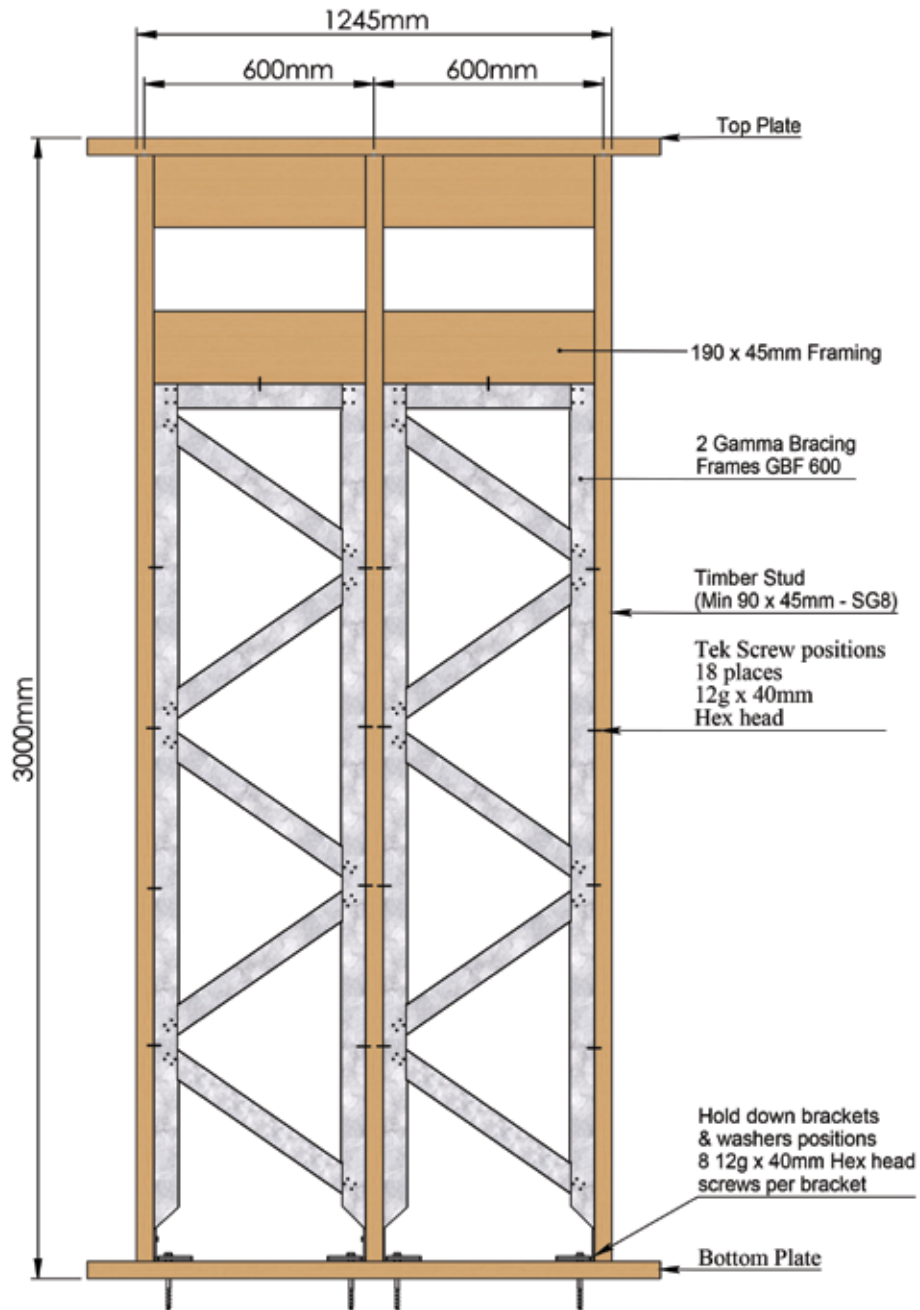

SPECIFICATIONS	
SYSTEM REF	GBF600/3.0 TWIN
WIND BUs	110
EARTHQUAKE BUs	120
WALL HEIGHT (m)	3.0
WALL LENGTH (m)	1.245

GBF 600/3.0 TWIN COMPONENTS LIST	
QTY	COMPONENT
2	GBF 600 FRAMES
4	GBF HOLD DOWN BRACKETS
4	GBF HOLD DOWN WASHERS
50	12 g X 40mm TEK SCREWS
TIMBER FRAMING MIN OF 90 x 45mm SG8 (BY OTHERS)	

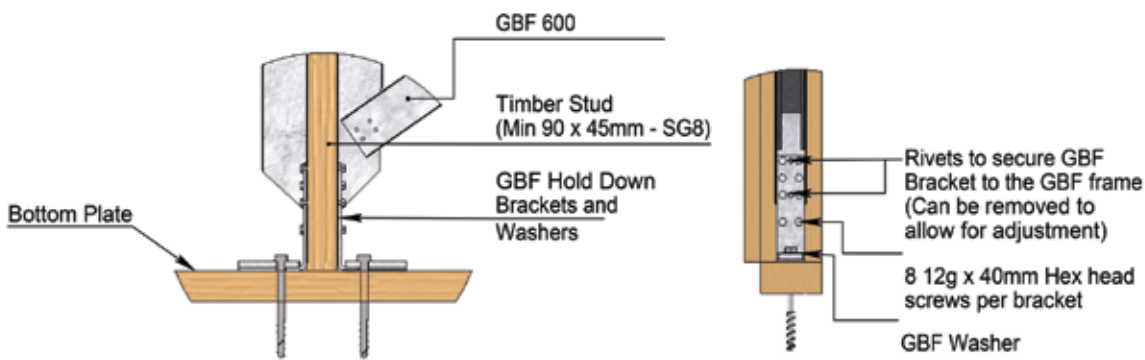
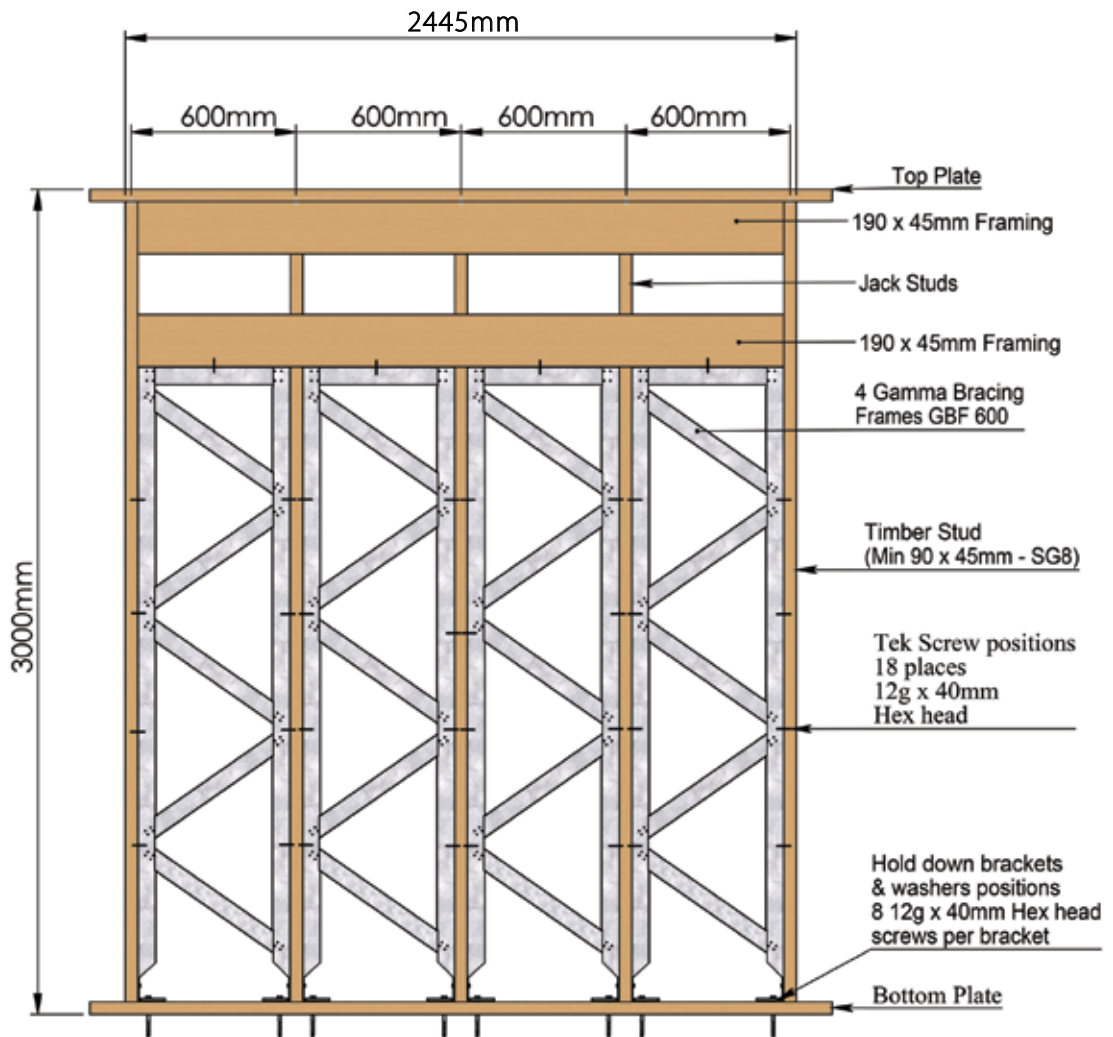

SPECIFICATIONS	
SYSTEM REF	GBF600 MULTI/3.0
WIND BUs	220
EARTHQUAKE BUs	240
WALL HEIGHT (m)	3.0
WALL LENGTH (m)	1.245

GBF 600 MULTI COMPONENTS LIST	
QTY	COMPONENT
4	GBF 600 FRAME
8	GBF HOLD DOWN BRACKETS
8	GBF HOLD DOWN WASHERS
100	12g X 40mm TEK SCREWS
TIMBER FRAMING MIN OF 90 x 45mm SG8 (BY OTHERS)	

EXTERIOR WALL ON CONCRETE FLOOR

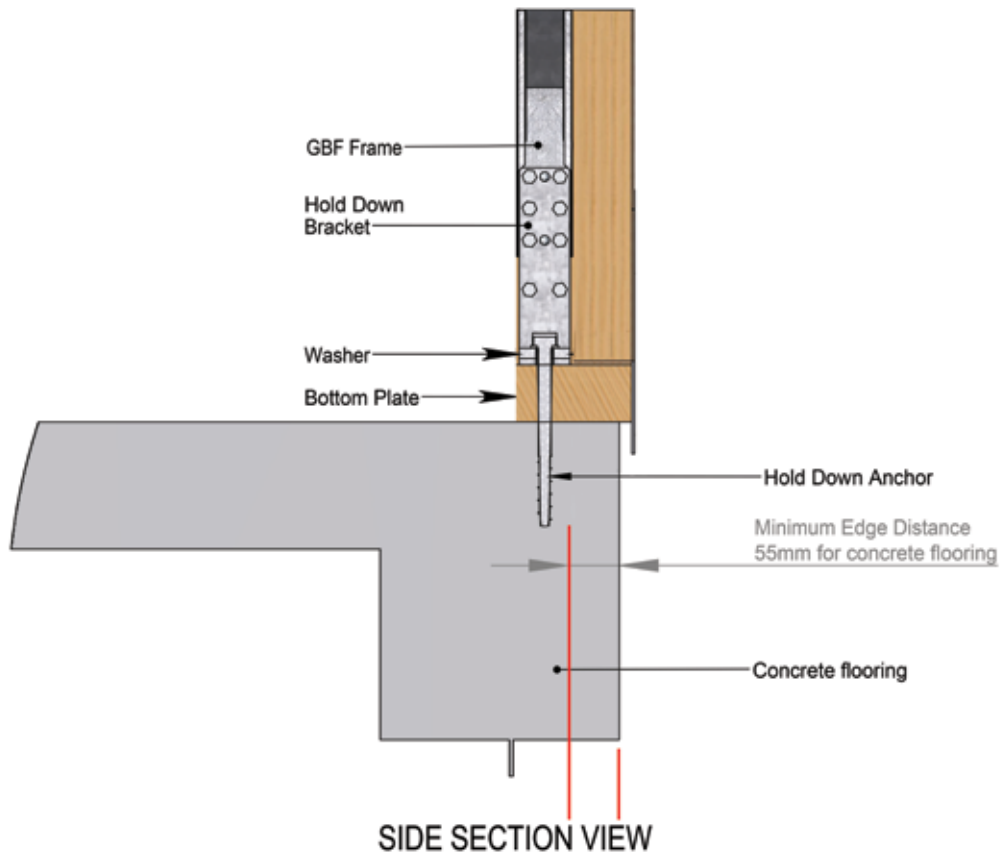
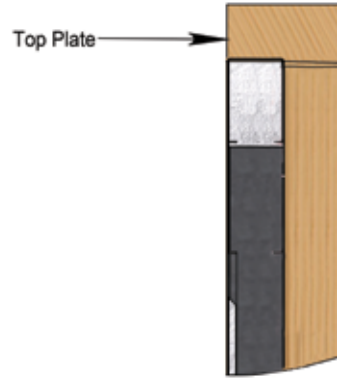

INTERIOR WALL ON CONCRETE FLOOR

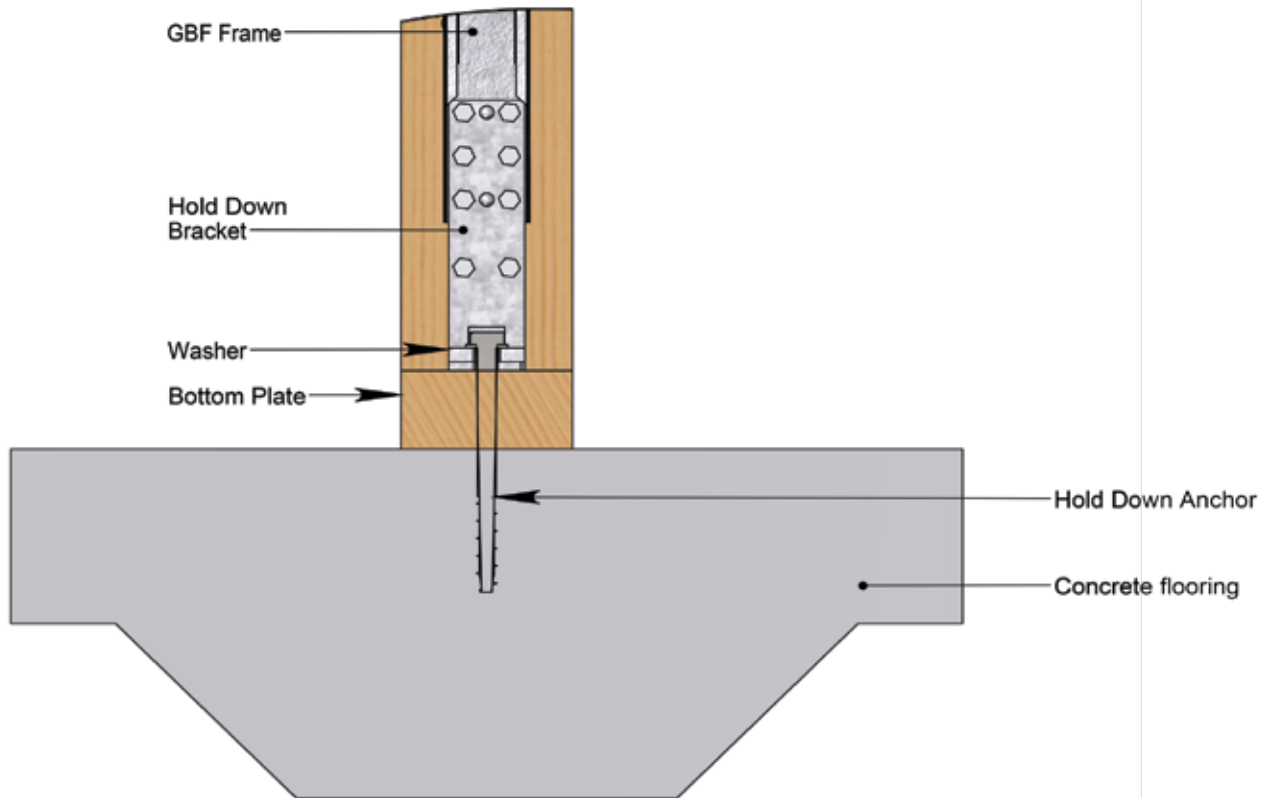

SIDE SECTION VIEW

EXTERIOR WALL ON TIMBER FLOOR

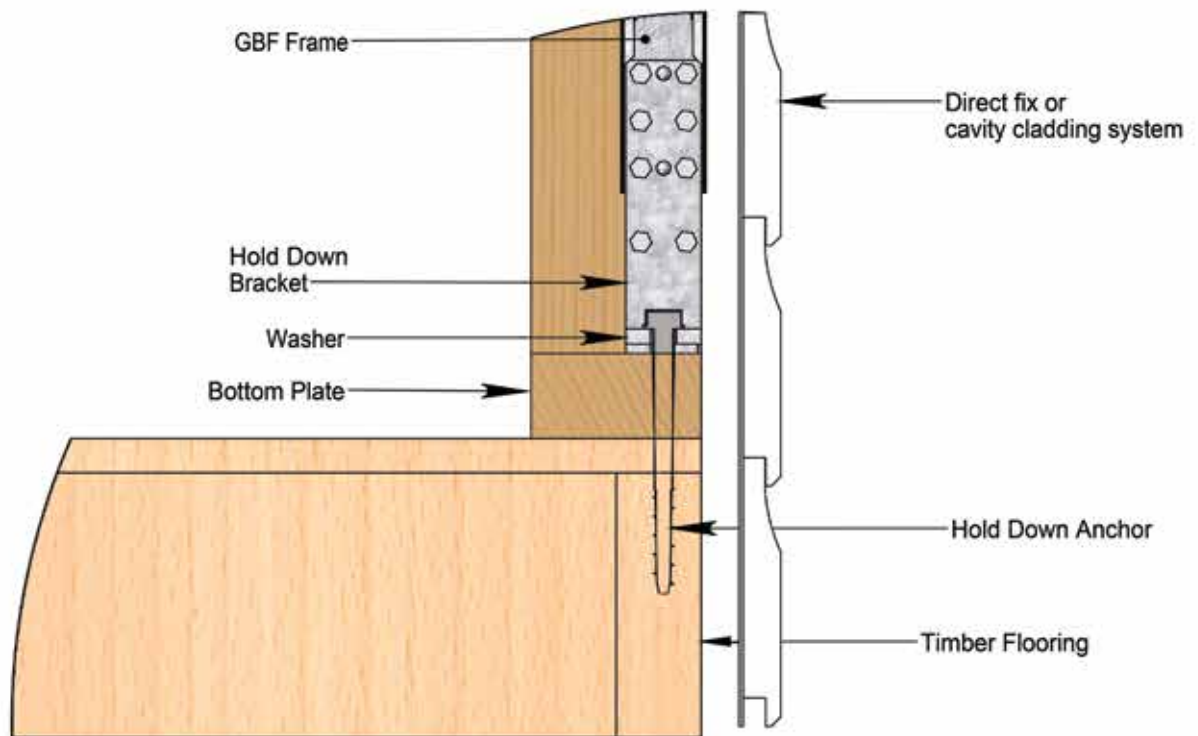

SIDE SECTION VIEW

INTERIOR WALL ON TIMBER FLOOR

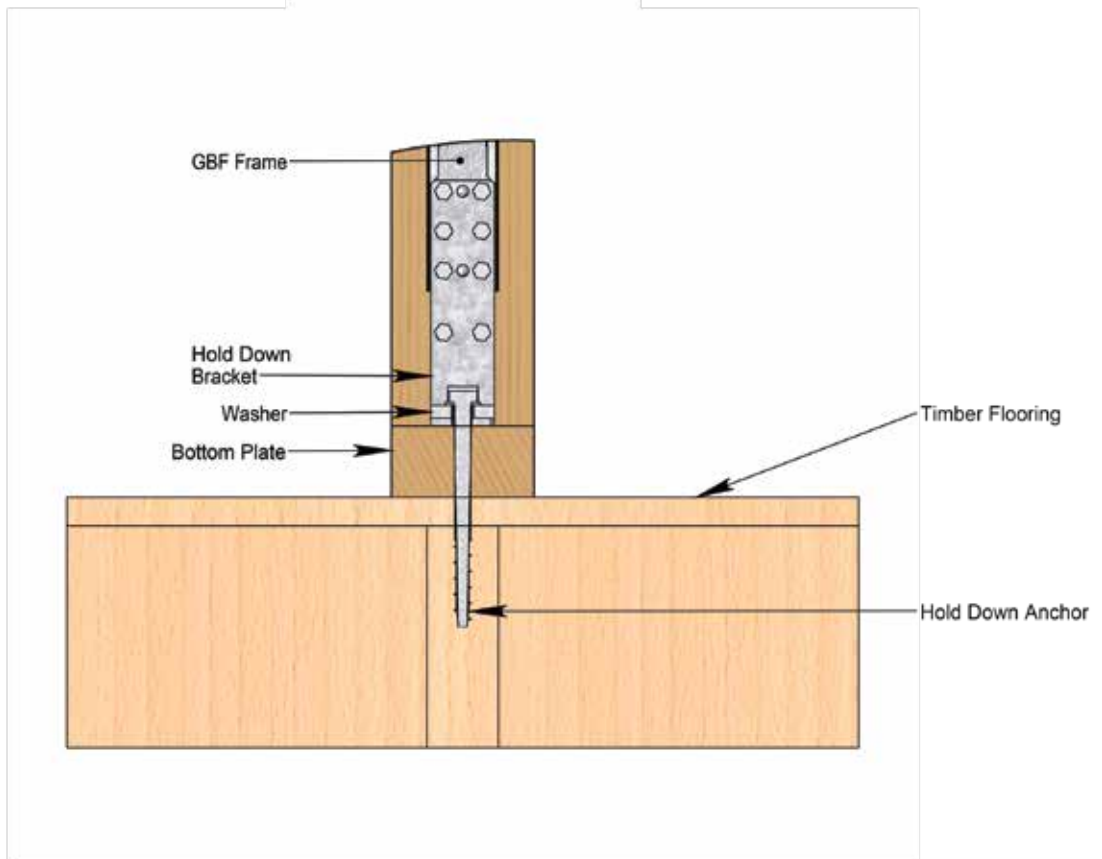
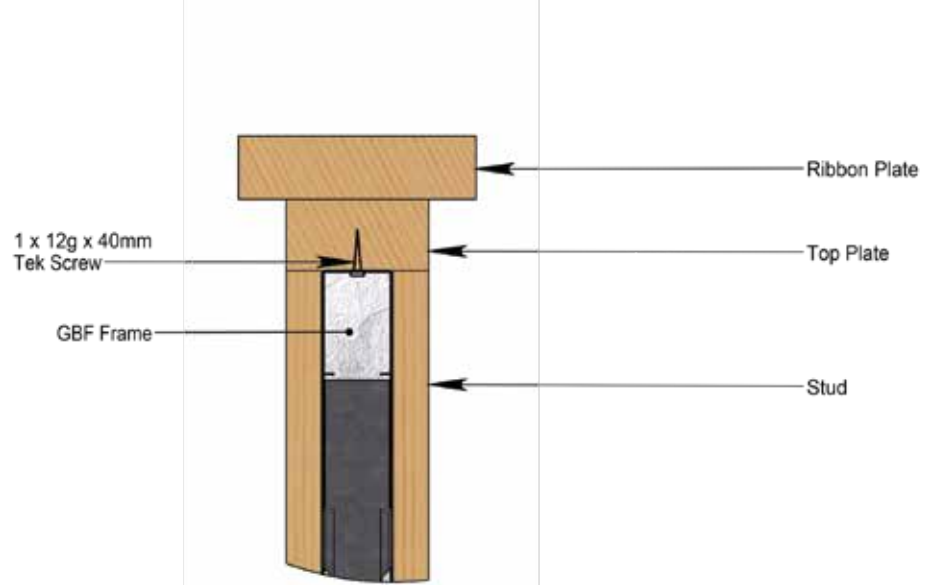

14.8 Construction Details - GBF Height Adjustment

The height of the Gamma Bracing frame can be adjusted to suit variations in the wall framing height or the alignment of the wall framing.

The height of the Gamma Bracing Frame can be increased by no greater than 50mm and decreased by no greater than 39mm to allow for any small deviation in wall framing height.

To adjust the height of the GBF it is permitted to remove the temporary rivet that hold each of the hold down brackets in place which allows the brackets to be adjusted up or down.

To increase the height of the GBF each of the hold down brackets will require adjusting downwards from the side channels of the GBF by a maximum of 50mm.

To decrease the height of the GBF each of the hold down brackets will require adjusting upwards into the side channels by a maximum of 39mm.

All 12g x 40mm Tek Screws MUST be installed to each of the hold down brackets and the GBF frame. (Qty of 8 Screws per Hold down bracket - supplied).

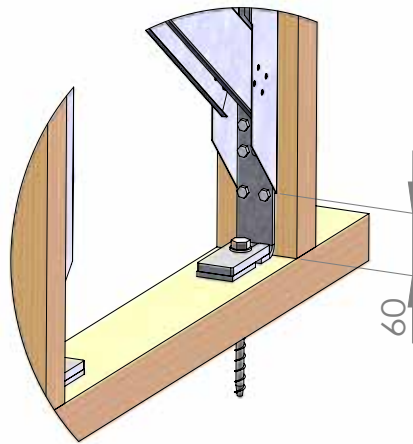

'25mm DOWN' POSITION

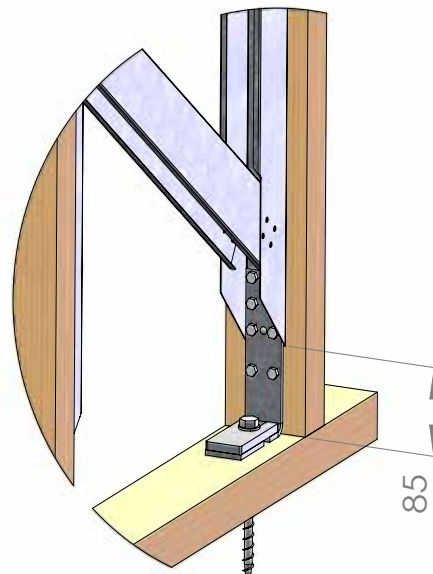

'AS SUPPLIED' POSITION

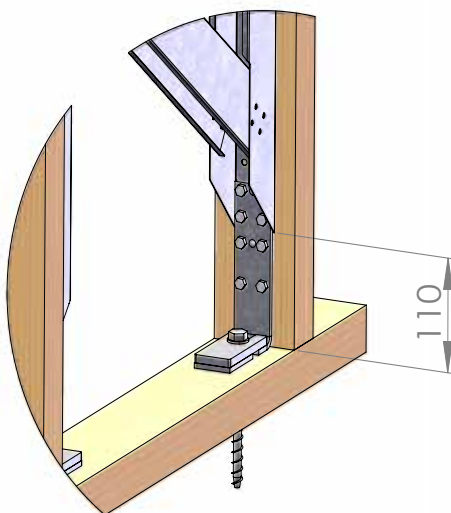

'25mm UP' POSITION

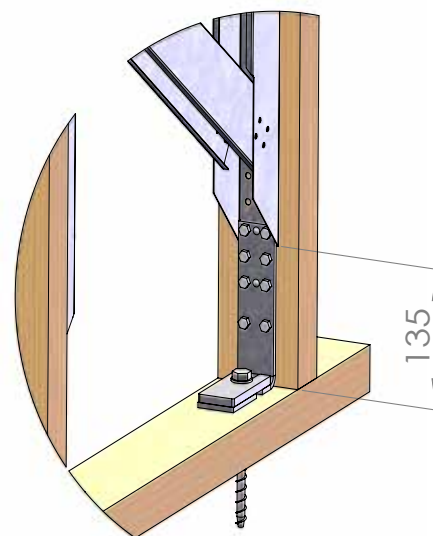

'50mm UP' POSITION

15.1 Fasteners

12g x 40mm Tek Screw



All Gamma Bracing Systems require fixing to the timber frame by the use of 12g x 40mm Tek Screws (provided). The quantity of Tek Screws varies for each system. Check the components list on each system page for the quantity of Tek Screws required.

15.2 Hold Down Anchors

TABLE 4 Hold Down Anchors			
Floor Type	Wall Type	Anchor Type	Uplift Capacity
Concrete	External Wall	**Masonry Screw	15kN
		Chemical Set Anchor	
		"J" Bolt set into Concrete	
Concrete	Internal Wall	**Masonry Screw	15kN
		Chemical Set Anchor	
		Expansion Bolt	
Timber	External/Internal Wall	M12 Coach Screws	12kN

** Gamma recommends the use of the Hilti HUS-H 10/140 Masonry Screw Anchor

15.3 Insulation

Where Gamma Bracing Frames are installed in exterior walls insulation is to be installed to meet the requirements of the New Zealand Building Code.

Insulation is to be installed within all areas and cavities of the Gamma Bracing Frame.

For further information regarding the types of insulation, please contact Gamma Bracing Technologies Ltd, Ph. 0800 272 733.



Fittings to Gamma Bracing Frames

15.4 Electrical Equipment

All electrical equipment must be installed by a Registered Electrician in accordance with AS/NSZ 3000:2017. Tables 5 & 6 below detail accessory fittings that can be installed to the Gamma Bracing frame. Other larger and heavier items such as sinks, toilet cistern's and wall mounted television screens will require mounting directly to the timber studs.

* Do not cut or modify the Gamma Bracing Frames as this will impede structural performance.

Additional timber frame may be required. Follow manufacturers installation instructions.

TABLE 5	Electrical Equipment		
	Electrical Accessories Type	Fastener Types	
		Rivets	Tek Screws
Electrical switch mounting box	1/8" to 1/4"	6g to 14g	M4 to M12
Electrical socket outlet box			
Electrical cables + mounting brackets clips			
Electrical wall mounted light fittings			
Telephone socket outlets			
Internet/Computer socket outlet			
Television Aerial outlets			
Data Cables + mounting bracket & Clips			
*Note - All electrical cables to be properly insulated. Use grommets where electric cables pass through service holes.			

Electrical flush mount boxes



15.5 Plumbing Equipment

TABLE 6	Plumbing Fitting Equipment		
	Plumbing Accessories Type	Fastener Types	
		Rivets	Tek Screws
Tap fittings + brackets	1/8" to 1/4"	6g to 14g	M4 to M12
Shower Head fittings + brackets			
Pipe work + mounting brackets/clips			
<ul style="list-style-type: none"> Galvanized Pipe PVC Pipe Copper Pipe (*Refer Note) 			
*Note - Ensure copper pipe is well insulated when installing with Gamma Bracing Frames. Contact between Copper and Galvanized Steel causes electrolysis resulting in the corrosion of components. Use of grommets in access holes and insulated brackets and saddles when mounting directly to Gamma Bracing Frames will be required.			

Insulated pipe mounting brackets and wing backed plumbing fittings



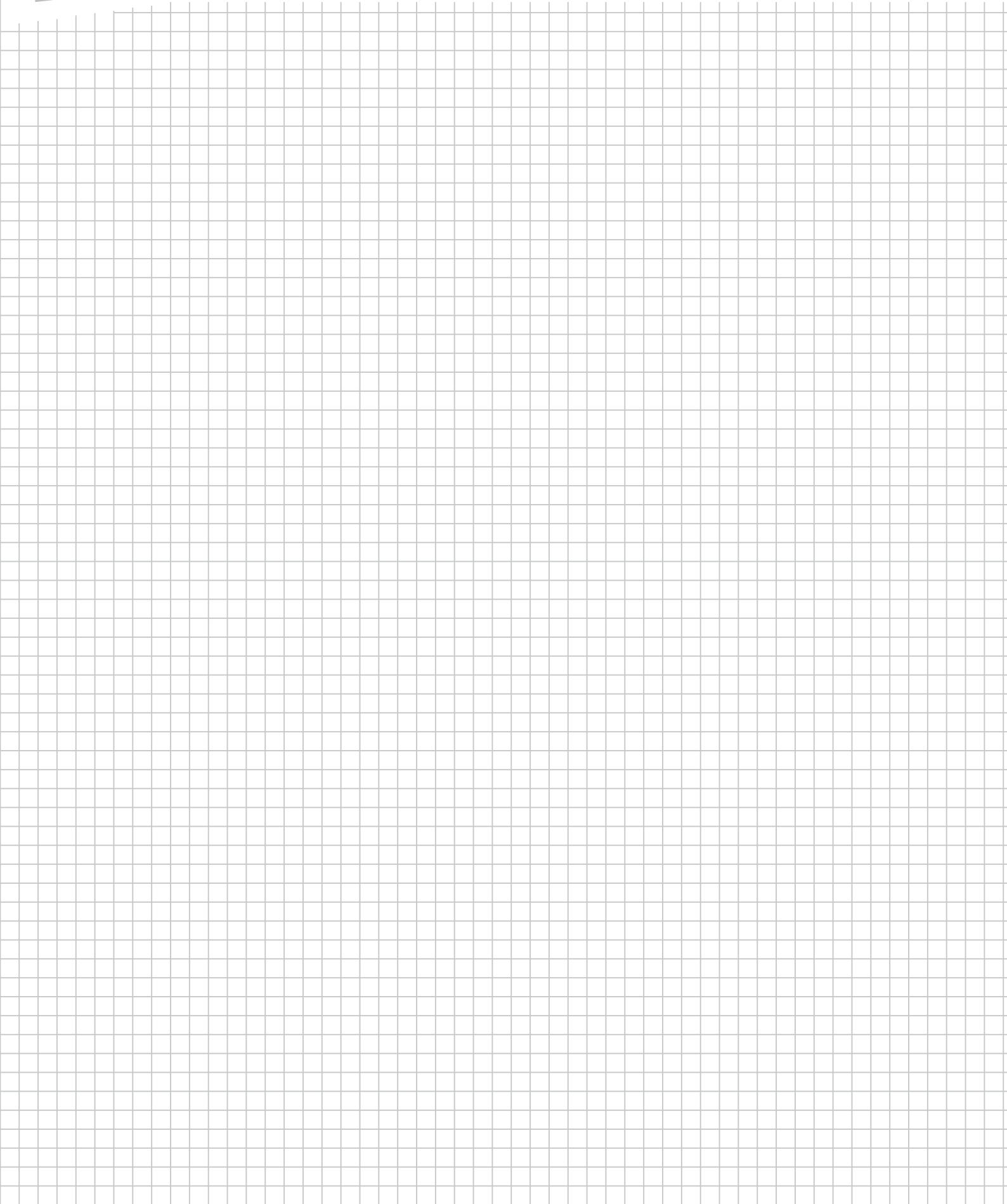



GAMMA BRACING FRAME



Contact:

FreePhone 0800 272 733

website www.gammabracing.co.nz

692A Beach Road
Browns Bay
New Zealand 0630

For detailed specifications the most current Gamma Bracing System's technical manual should always be referred to.

© 2014 Copyright: all the material in this document including all text, tables, diagrams and illustrations are protected by copyright.

In order for **Gamma Bracing Systems** to perform as tested all components must be installed exactly as prescribed.

Substituting components produces an entirely different system and may seriously compromise performance.

Where specified, correct components must be used when installing and specifying **Gamma Bracing Systems**.



Copyright 2014

TECHNICAL & SALES 0800 272 733

www.gammabracing.co.nz